



ODISHA RENEWABLE ENERGY DEVELOPMENT AGENCY, BHUBANESWAR

BID DOCUMENT

FOR

Design, Manufacture, Supply, Installation (Erection), Testing, Commissioning, including Warranty and Comprehensive Maintenance Contract for a period of 5 years of Solar energy based dual pump pipe water supply schemes in the state of Odisha under RWS&S and other Govt Dept on **Rate Contract**.

Date of release of bid	Dt.15.05.2018
Pre-bid meeting held	Dt. 28.05.2018 at 11.30 AM
Final online bid document hoisting	Dt. 30.5.2018
Date and time of last submission	Dt. 20.06.2018 at 5.00 PM Online Dt.23.06.2018 at 1-00 PM hard Copy
Opening of Techno-commercial bid (Part-I)	Dt. 23.06.2018 at 3-30 PM
Date of opening of the price bid(part-II)	To be informed to the qualified bidders.

E-TENDER CALL NOTICE No.1786

DATE-14.05.2018

S-3/59, MANCHESWAR INDUSTRIAL ESTATE, BHUBANESWAR-751010

Phone : (0674) 2588260,2586398,2580554. Fax:2586368

Website: www.oredaorissa.com, Email: ceoreda@oredaorissa.com

Background

Solar energy based dual pump piped water supply scheme:

Bore well / tube wells are the only sources of drinking water in small / inaccessible / habitations. When water level in the wells depletes or hand pumps go out of order providing minimum life supporting drinking water in these villages comes as a very big challenge. Since most of these habitations are either un-electrified, power starved or the power supply is highly erratic energising the wells with normal grid power is also very difficult. Frequent natural calamity disrupts the normal water supply due to grid failure. In such scenario Solar PV water pumping systems in tandem with regular existing hand pumps (called as dual pump) emerge as viable option for ensuring uninterrupted drinking water supply with minimum recurring expenses.

Over the years it has come to experience that bore recharging capacity (yield), bore dimension, freak storm, tornado, cyclone, lightning, slow but longer operation period from morning etc are the factors to be taken into utmost consideration in implementation of the scheme. It is observed that 675 kwp solar PV module and slim submersible pumps to fit into the 4 bore well are most suitable. Solar submersible pumps with proven performance record of 5 years or so will be considered only.

About 2000 or more villages/habitations will be covered under the program. RWS&S and other Depts., DMF will provide the full finance; list of villages, locations of the bore wells within the village and water yielding report of each selected bore well. Two models are proposed. One with model mounting structure separately with mono pole for cyclone / nor'wester (tornado) / lightning prone areas, another with solar module top of the OHT for other areas.

In view of the large geographical spread and limited time available for completion of the project it is contemplated to allocate the supply / installation to 10 maximum technically qualified bidders. This is subject to their acceptance of the L1 price discovered through the tender subject to condition that qualified L1 bidder shall have the claim of minimum 30% of the allocation on successful performance on phase wise firm work order. No new local vendor of MSME / Start up / Entrepreneur category is allowed. The firms who are already associated in the local category will be considered depending upon the overall performance in works already assigned, if any.

CONTENTS

Sl No	Items	Page
1	Disclaimer	4
2	Notice inviting tender	5-6
3	Instruction to bidder online	7-9
4	Submission of bid online	10-12
5	Checklist of documents to be submitted	13-14
6	Undertakings by bidders	15
7	Letter of Authorisation	16
8	The Scope of work	17-19
9	Eligibility Criteria	20
10	Instructions to Bidder	21-25
11	Commercial terms and conditions	26-32
12	Technical specification	33-44
13	All format annexure	45-47
14	Scope of CMC	48-51
15	BG format	52-55
15	Price bid for online only, not in hard	56-60

Disclaimer

Kindly Note:

1. This document is not transferable
2. Though adequate care has been taken for preparation of this document, the bidder shall satisfy himself that the document is complete in all respects. Intimation of any discrepancy shall be given to this office immediately. If no intimation is received from any bidder on the pre bid meeting or within ten days from the date of issue of the bid document, it shall be considered that bid document is complete in all respects and has been received by the bidder.
3. The Odisha Renewable Energy Development Agency (OREDA) reserves the right to modify, amend or supplement this bid document keeping in view the necessity in implementation of the scheme.
4. While the bid document has been prepared in good faith, neither OREDA nor their employees or advisors make any representation, warranty, express or implied or accept any responsibility or liability, whatsoever, in respect of any statements or omissions herein, or the accuracy, completeness or reliability of information, and shall incur no liability under any law, statute, rules or regulations as to the accuracy, reliability and completeness of this bid document, even if any loss or damage is caused by any act or omission on their part.

ODISHA RENEWABLE ENERGY DEVELOPMENT AGENCY

S-3/59, MANCHESWAR INDUSTRIAL ESTATE, BHUBANESWAR-751010

Phone : (0674) 2588260,2586398,2580554. Fax:2586368

Website: www.oredaorissa.com, Email: ceoreda@oredaorissa.com

NOTICE INVITING E-TENDER NO: 1786 /OREDA

DTD-14.05.2018

ODISHA RENEWABLE ENERGY DEVELOPMENT AGENCY invites sealed e-tenders **in two part bidding system** from manufacturer, system integrator for Design, Manufacture, Supply, Installation (Erection), Testing, Commissioning, including Warranty and Comprehensive Maintenance Contract for a period of 5 years of Solar energy based dual pump pipe water supply schemes in the state of Odisha under RWS&S and other Govt Depts on rate contract.

Date of release of bid	Dt.15.05.2018
Pre-bid conference	Dt. 28.05.2018
Revised & final online bid document hoisting	Dt. 30.5.2018
Date and time of last submission	Dt. 20.06.2018 at 5.00 PM Online
Date and time of submission of hard copy of documents.	Dt.23.06.2018 at 1-00 PM hard Copy
Opening of Techno-commercial bid (Part-I)	Dt. 23.06.2018 at 3-30 PM
Date of opening of the price bid(part-II)	To be informed to the qualified bidders.

Interested prospective bidders may visit OREDA's website www.oredaorissa.com and www.tenderwizard.com/OREDA for details relating bidding process and all other terms and conditions. The bidders can view the tender documents from www.oredaorissa.com website free of cost.

Sd/dt.10.5.2018
Chief Executive, OREDA

ODISHA RENEWABLE ENERGY DEVELOPMENT AGENCY
 S-3/59, MANCHESWAR INDUSTRIAL ESTATE, BHUBANESWAR-751010
 Phone : (0674) 2588260,2586398,2580554. Fax:2586368
 Website: www.oredaorissa.com, Email: ceoreda@oredaorissa.com

DETAIL OF NOTICE INVITING TENDER

ODISHA RENEWABLE ENERGY DEVELOPMENT AGENCY invites sealed e-tenders **in two part bidding system** from manufacturer, system integrator, EPC firms for Design, Manufacture, Supply, Installation (Erection), Testing, Commissioning, including Warranty and Comprehensive Maintenance Contract for a period of 5 years of Solar energy based dual pump pipe water supply schemes in the state of Odisha under RWS&S and other Govt Depts on rate contract.

Particulars	Estimated Cost (Rs. in .Lakhs)	Earnest Money Deposit (Rs. In Lakhs)	Tender processing fee Non refundable (in Rs.)	Non refundable Cost of Bid document	Last date/time for submission of bids	Date and time of opening of bid
Supply, installation, commissioning including warranty and Comprehensive Maintenance Contract for a period of 5 year of solar energy based dual pump pipe water supply systems complete in all respect with independent riser pipe as per the technical specification, schedule of materials and terms and condition of the of the work award from time to time on the basis of the price arrived at within a period of minimum one year of the valid tender under the scope of work	1500 project likely to enhance to 30 % 80,00,000,00	20,00	2300 and other fees	Rs. 10500/-	Dt. 20.06.2018 at 5.00 PM Online Dt.23.06.2018 at 1-00 PM hard Copy	Dt. 23.06.2018 at 3-30 PM

Interested prospective bidders may visit OREDA's website www.oredaorissa.com and www.tenderwizard.com/OREDA for details relating bidding process and all other terms and conditions. The bidders can view the tender documents from www.oredaorissa.com website free of cost. The authority reserves the right to accept / reject any part thereof or all the bids without assigning any reason.

Sd/-10.5.2018

Chief Executive, OREDA

ONLINE SUBMISSION OF BID

General Information

- i) Interested bidders may visit OREDA's website www.oredaorissa.com or www.tenderwizard.com/OREDA for details. **Tender documents can be viewed free of cost.**
- ii) Bidders who want to submit bid shall have to pay the **tender cost**. The tender cost is required to be paid in shape of **Demand draft** only, drawn in **favour of Chief Executive, OREDA payable at Bhubaneswar**. The tender cost is inclusive of taxes and is non refundable.
- ii) The bidders shall have to submit the non-refundable tender processing fee in e-payment mode only. The processing is inclusive of service tax.

(NOTE: For tender processing fee to K.S.E.D.C. Ltd. Bangalore, the bidder can use various modes of e-payment facility available through Tender wizard Portal, i.e. by Credit Card, Debit Card, Net Banking).

- iv) The bidders shall have to scan the Demand Draft / Bank guarantee towards **EMD, Tender Cost, Signed copy of** unconditional acceptance of all terms and conditions of the tender, **Signed copy of** Confirmation to Technical Specifications and all **other documents as required in the tender** and upload the same in the prescribed form in .pdf or .jpg format in addition to sending the originals.
- v) The bidders are advised to register their user ID, Password, company ID on website www.tenderwizard.com/OREDA by clicking on hyper link "**Register Me**".
- (v) Any clarifications regarding the scope of work and technical features of the project can be had from the undersigned during office hours

NB: All subsequent addendum/Corrigendum to the tender shall be hoisted in OREDA's official web site www.oredaorissa.com and www.tenderwizard.com/OREDA only.

For and on behalf of OREDA

A. MODE OF SUBMISSION OF BID:-

- i) The bidder shall submit the bid in Electronic Mode only i.e. in www.tenderwizard.com/OREDA portal. The bidder must ensure that the bids are received in the specified website of the OREDA by the date and time indicated in the Tender notice.
- ii) Bids submitted by telex/telegram will not be accepted.
- iii) The OREDA reserves the right to reject any bid, which is not submitted in electronic mode and according to the instruction, stipulated above.

(A-I) PARTICIPATION IN e-TENDER:-

ACQUISITION OF DIGITAL SIGNATURE CERTIFICATE

- i) For all the users it is mandatory to procure the Digital Signatures of **Class III only**.
- ii) Contractors / Vendors / Bidders / Suppliers are requested to follow the following steps for registration.

(A-2) REGISTRATION IN TENDER WIZARD PORTAL

- i) Log in www.tenderwizard.com/OREDA Click “Register”, fill the online registration Form.
- ii) Payment shall be made to KSEDCL, Bangalore for vendor registration in tender wizard portal in **e-payment** mode only.
- iii) As soon as the verification is done the e-tender user ID will be enabled/provided.

(A-3) ON-LINE REQUEST FOR e-TENDER DOCUMENTS.

After viewing Tender Notification in www.tenderwizard.com/OREDA if bidder intends to participate in tender, he has to use his e-tendering User ID and Password which has been received after registration and acquisition of DSCs (Digital signature certificate). If any Bidder wants to participate in the tender he has to follow the instructions given below.

1. Insert the PKI (which consists of your Digital Signature Certificate) in your System.
(Note: Make sure that necessary software of PKI be installed in your system)
2. Click / Double Click to open the Microsoft Internet Explorer
3. (This icon will be located on the Desktop of the computer).
4. Go to Start > Programs > Internet Explorer. Type www.tenderwizard.com/OREDA in the address bar, to access the Login Screen.
5. Enter e-tender User Id and Password, click on “Go”. Click on “Click here to login” for selecting the Digital Signature Certificate. Select the Certificate and enter DSC Password. Re-enter the e- Procurement User Id Password
6. Click “Un Applied” to view / apply for new tenders.
7. Click on Request icon for online request. After making the request, bidder has to pay the requisite tender processing fee (as indicated in tender notice) through **e-payment** facility only available in the portal. Bidders will receive the Tender Documents which can be checked and downloaded by following the below steps.
8. Click to view the tender documents which are received by the user. Tender document screen appears.
9. Click “Click here to download” to download the documents.

NOTE: For vendor registration and payment of tender processing fee to KESDCL, the bidder can use various modes of e-payment facility available through Tender wizard Portal, i.e. by Credit Card, Debit Card, Net Banking.

(B) ONLINE SUBMISSION OF BID

The bidders shall have to scan the Demand Draft / Bank guarantee towards **EMD , Tender Cost, signed copy** of “unconditional acceptance of all terms and conditions of the tender”, Signed copy of “confirmation to technical specification” and **other documents** as required for the tender and **upload** the same in the prescribed form in .pdf or .jpg format in addition to sending the original **except bid sheets (.xls)** prior to last date and time of receipt of bids as specified in tender Notice. Tender processing fees is mandatory & to be paid on **e-payment** mode as stated elsewhere in the document. The attachments should be properly renamed before uploading.

(B-1) PROPER FILLING UP OF THE PRICE SCHEDULE:

The bidder should fill up the Techno commercial and price schedule properly in the bid sheets provided in .xls format and up-load the same without changing the file name. The tender may be rejected if the schedule of price is submitted in incomplete form.

NB: The bid sheets (.xls file) shall be uploaded in www.tenderwizard.com/OREDA portal, prior to online closing of the tender. By no other means (except online) price bid shall be accepted for evaluation of tender.

- i. After completing all the formalities, Bidders will have to submit the tender as specified in NIT and must take care of all instructions. Prior to submission, verify whether all the required documents have been attached and uploaded to the particular tender or not.

Note down / take a print of bid control number once it displayed on the screen

- ii. Tender Opening event can be viewed online.
- iii. Competitors bid sheets are available in the website for all participated bidders.

For any assistant, Contact:

E-Tendering help desk number: 080-

40482000/121/133/140(Bangalore) OREDA Help Desk-

09776823641/09937140591

NOTES:

(C) DEAD LINE FOR SUBMISSION OF BIDS

- i) Soft copy of the bid shall be uploaded through the portal www.tenderwizard.com/OREDA on or **before the online submission time and date as stipulated in the bidding document.**

DD towards Tender cost, DD/BG towards Bid Security, tender processing fee acknowledgement & a set of all uploaded documents including uploaded Techno-commercial Bid must be received by OREDA at the address specified not later than the time and date stated in the tender notification.

- ii) In the event of the specified date for the submission of bids being declared a holiday for OREDA, the bids will be received on the next working day as per the time indicated in tender notification.
- iii) OREDA may, at its discretion, extend this deadline for submission of bids by amending the Bidding Documents in accordance with Instruction to Bidders for the reasons specified therein at any time prior to opening of, in which case all rights and obligations of Employer and bidders will thereafter be subject to the deadline as extended.

(D) LATE BIDS

- i) Soft copy of the bid will not be uploaded on the portal after expiry of submission time and the bidder shall not be permitted to submit the same by any other mode. In such case, even if the bidder has submitted the specific documents in hard copy in original (viz., bid security, tender cost & any other document) within the stipulated deadline, its bid shall be considered as late bid. The hard copy submitted [specific documents (viz., bid security, tender cost.)] shall be returned unopened to the bidder.
- i) Hard copy of the bid security i.e EMD in shape of DD/BG if received by OREDA after the last date for submission of the bid the same will be considered as late bid even if the bidder has uploaded the soft copy of the bid within the stipulated deadline. In such a case, the soft part of the bid uploaded on the portal shall be sent unopened to "Archive" and shall not be considered at all any further.

(E) MODIFICATION AND WITHDRAWAL OF BIDS:-

- i) Bidder may modify or withdraw their bids through the relevant provisions on the portal www.tenderwizard.com/OREDA **up to due date and time of submission of bid indicated in tender notification**
- ii) The Bidders may modify and resubmit their bids as per the provisions given in the portal.
- iii) Bidders may withdraw their bids through the relevant provisions of mentioned in the portal.
- iv) **No bid shall be modified/ withdrawn after the dead line for submission of bids. Withdrawal/modification of bid before the expiry of bid validity shall result forfeiture of Bidder's bid security.**

SUBMISSION OF HARD COPIES OF THE BIDS AND SEALING AND MARKING:-

(A) Hard copies of the following items should only be submitted to OREDA

All the papers of bid documents as per the check list **except the price bid** duly signed & should be uploaded in **e-tender** portal. Hard copy (i.e EMD, Tender cost & signed e-tender document) shall be submitted OREDA office at S-57, Mancheswar Industrial Estate, Bhubaneswar 751010 before tender closing date and time.

Submission of any documents other than the asked documents can't be received at any cost. This may lead to the rejection of bid.

(B) Technical bid:

The Electronic Form/Template of the bid for the Techno-Commercial bid, as available on the portal, shall be duly filled and scanned copies of documents in support of meeting the minimum qualifying requirement of the tender shall be given as attachments.

(C) Financial bid:

The Electronic Form/Template of the Price bid (as available on the portal) shall be duly filled in.

Any condition in regards to financial aspects, payments, terms of rebate etc beyond the prescribed financial terms of OREDA will make the bid invalid.

Therefore it is in the interest of the bidders not to write anything extra in the Price Bid except price.

ACCEPTANCE/REJECTION:

OREDA reserves the right to accept / reject any or all Tenders without assigning any reason thereof and alter the quantity of materials mentioned in the Tender documents at the time of placing purchase orders. Tender will be summarily rejected if:

- i) Bid security is not deposited either in shape of Bank Draft in favor of OREDA payable at Bhubaneswar or in Bank Guarantee.

Note: Bid security against previous Tenders, if any, will not be adjusted towards Bid security against this Tender.

- ii) Complete Technical details are not enclosed.
- iii) Tender is received after the last date for what-so-ever reasons.

PROCEDURE FOR OPENING THE BIDS:

The procedure of opening of the bid shall be as under

- The TECHNICAL BID shall be opened at the time & date mentioned in the bid notice by OREDA in the presence of bidders, who choose to be present. If necessary, the firms may be called for Technical Presentation the schedule for which will be intimated by OREDA.
- The Price bid shall be opened after evaluation of technical suitability of the offers. The date for opening of Price bid shall be communicated subsequently. The Price Bid of only those bidders shall be opened who qualify in the technical bid.

****Contactors/Vendors are advised to upload their tender documents well in advance to avoid last minutes disappointment.***

Check list of documents to be submitted along with the bid

Sl no	Particulars	Compl ied	Page-no / Flag
1	Bank draft for Rs.10,500/- or or exempt as admissible with proof of exemption	Bank No Dt	Envelope
2	Bank draft for Rs.40,00,000/- towards Earnest Money deposit or exempt as admissible with proof of exemption	Bank No Dt	Envelope
3	Forwarding letter & Undertaking duly signed and stamped by the bidder. Undertaking to unconditionally accept all terms and conditions of the bid document with the endorsement by Board Resolution		
4	Valid document registering the status of the bidder as manufacturer /systems integrator / MNRE Channel Partner		
5	Copy of the PAN card of the bidder's firm		
6	Copy of the GST card of the bidder's firm		
7	Copies of Tax clearance certificate / returns latest		
8	Document summarised average annual turnover of 20 crore for last three years or as relaxed duly signed and stamped by a registered chartered accountant on the letter head of the Chartered Accountant		
9	Proof of installation of min 500 pumps (AC / DC / surface / submersible) with min 50 dual pumps in the entire country in Govt / PSU / Govt Agencies or as relaxed . Copies of certificates given by the concerned government agencies to be enclosed		
10	A self certificate on not debarred / black listed / default		
11	Valid Test reports of Solar PV BLDC water pumping systems of 675 Wp capacity in the name of the bidder from valid MNRE accredited test lab		
12	Undertaking for Indigenusness (domestic content) of the supplied items		
13	Filled in bid document duly signed and stamped at the bottom of each page except the price bid format.		

Forwarding Letter

(To be submitted in the letter head of the bidder)

To,

Chief Executive
Odisha Renewable Energy Development Agency
S-59, MIE, Bhubaneswar-751010
Odisha

Subject: Submission of tender for the supply / installation of Design, Manufacturing, Testing, Supply, Installation, Commissioning & Maintenance of **Solar energy based dual pump piped water supply.**

Sir,

I/We have also read the various provisions of the Tender and confirm that the same are acceptable to us including the provision of CMC. We further declare that any additional conditions, variations, deviations, if any, found in our Tender offer shall not be given effect to. We further understand that **any deficiency / illegibility in documents shall make our tender liable for rejection.**

I/we submit our tender understanding fully well that

- (a) The bid and other documents submitted along with the same will be subject to verification by appropriate authorities.
- (b) OREDA reserves the right to accept or reject any application or the bid process itself without assigning any reasons thereof and shall not be held liable for any such action.
- (c) Any genuine changes made by the department in the interest of the work with respect to the technical requirement during the course of project implementation will be acceptable.

We hereby declare that all the information and statements made in this proposal are complete, true and correct and also accept that any misinterpretation contained in it may lead to our disqualification.

We hereby declare that our Tender is made in good faith and the information contained is true and correct to the best of our knowledge and belief.

Yours faithfully,

Signature of the Bidder with Seal

UNDERTAKING BY THE BIDDER

I/we here by undertake that

1. We have thoroughly read and examined the notice inviting tender and the tender document along with all its schedules, annexure etc.
2. The rates quoted by us are firm and final and are meant for execution of the allotted supply / installation within the time frame stipulated in the tender/supply / installation order.
3. All terms and conditions of the tender including the rates quoted by us shall remain valid for a period of min one year from the date of opening of the technical bids.
4. In case our tender is incomplete in any respect or we violate any of the prescriptions given in the tender for submission of the same OREDA shall , without prejudice to any other right or remedy , be at liberty to disqualify us.
5. In case of award of supply / installation in our favour OREDA shall have the right to convert the EMD deposited by us in to full or part (as the case may be) of the security deposit to be deposited by us against award of the supply / installation.
6. In case we fail to commence or complete the supply / installation as per the time schedules or fail to fulfill any of the terms and conditions given in the tender OREDA shall , without prejudice to any other right or remedy , be at liberty to forfeit the security deposit made by us against the award of the supply / installation.
7. I/We hereby declare that I/We shall treat the tender documents, specifications and other records connected with the supply / installation as secret/confidential and shall not communicate information derived there-from to any person other than a person to whom I/We have authorized to communicate the same or use the information in any manner prejudiced to the safety of OREDA/the State Govt.
8. I/We shall abide by all the laws prevailing at the time of the execution of the supply / installation and shall be responsible for making payments of all the taxes, duties, levies and other Govt. dues etc. to the appropriate Govt. departments.
9. The entire tender document has been discussed in the Board meeting and a resolution has been concurred for participation in the tender (copy enclosed)
10. We are not blacklisted / debarred / defaulted in any manner by any Central / State Government / Public Sector Undertaking in India.
11. In case any false documents submitted and found any time in future the firms shall be liable to be proceeded against as per prevailing laws.
12. Our state tax registration no. is _____ and the PAN No. under the Income Tax Act is _____
10. I/We shall be responsible for the payment of the respective taxes to the appropriate authorities and should I/we fail to do so, I/we hereby authorize OREDA to recover the taxes due from us and deposit the same with the appropriate authorities on their demand.
- 11.

Signature of bidder with stamp & date

Letter of Authorization

(to be submitted in the letter head of the bidder)

To,
Chief Executive
Odisha Renewable Energy Development Agency
S-59, MIE, Bhubaneswar-751010
Odisha

Sub: Submission of tender for the supply / installation of Design, Manufacturing, Testing, Supply, Installation, Commissioning & Maintenance of **Solar energy based dual pump piped water supply.**

Ref: Tender Call **Notice No. -----/ OREDA, dtd -----.**

Sir,

I/we hereby authorise Ms. /Mr. _____, Designationof our company to sign all relevant documents on behalf of the company/firm in dealing with the above tender. She / He is also authorized to attend all meetings and submit technical and commercial information as may be required by OREDA in the course of processing of the tender.

We further authorise Ms. /Mr. _____ designation..... of our company to make technical presentation on behalf of the company, if called for.

Signature of the authorise persons

1. _____
2.

Signature attested

Name and designation of the attesting officer with stamp.

Yours faithfully
Head of the organization

1. Scope of Works.

The broad scope of the supply / installation includes design, manufacture, supply, installation, testing commissioning, warranty, operation & Maintenance for 5 years for supply / installation of Solar energy based dual pump piped water supply system providing Solar Photovoltaic pumps sets along with MS stage, storage tank, piping, stand post adhering to the standardized norm / BIS /MNRE specification (as per the valid test report issued to the bidder of the authorized test centre) as per the work order from time to time in the entire state in the year 2017-18/ 2018-19.

All tax deductions at source applicable for turnkey contract will be made irrespective of GST clearance documents subject to bifurcation of the price components.

- a) Collection of the list of village including, locations of the bore wells, water discharge testing reports, shadow free area etc from OREDA / Users Agency.
- b) Visit to the village and identifying the designated bore well and selection of site for construction of over head tank at a higher location and stand posts as per the requirement and intimating the concern EE RWSS/ VWSC about the date and time of commencement of supply / installation.
- c) Deciding the location of stage and the stand post required in habitations after discussing with the elected representative / VWSC / authorised officer of RWSS.
- d) Transportation of all materials to the village and keeping the same in safe own custody within village. OREDA shall not be the consignee to receive the materials supplied/ delivered.
- e) Installation of the solar PV submersible water Pump, MS Stage, storage water tank, solar PV array, required stand post, soak pit and pipeline for water dispensation etc. as per the technical specifications, prevailing standards provided in the tender and testing the same in the presence of the VWSC/ authorised officer of RWSS/ User's Agency. In case of sanitary well the float arrangement to provide.
- f) Installation of the water dispensing stand post including construction of its platform etc. in a manner which is convenient for collection of water. The system shall be away from the water outlet portion. Outlet pipes for tube well shall not be exposed over the platform.
- g) After initial operation and testing of the pump for about a week handing over the same to the Village Committee/authorised officer of RWSS to be maintained by the firm for 5 years under CMC.
- h) Collection of all documents, including photographs of the installed systems and preparing the joint commissioning reports.

- i) Submission of all documents as detailed in the tender document including the joint Commissioning report to OREDA
- j) Periodic maintenance of the system as detailed in this tender.
- k) Opening of service centre/keeping servicing personnel and making available all essential spares in the vicinity of the solar water pumping system will give the desired performance with least interruption.
- l) Submission of periodic reports and returns as per the MIS prescribed by OREDA from time to time.
- m) Supply of the complete systems, including all necessary components, sub-components, spares, tools, tackles etc. as per technical specifications given in this document including packing, forwarding, safe storage, handling, commissioning, trial and performance testing and handing over, insurance.
- n) The solar panel shall be warranted for ten years with rated performance. Security cum PGF for the corresponding amount for the period warranty is to be retained by this office.
- o) Solar submersible pumps of 675 Wp capacity depending upon the yield of bore well will be utilized for the purpose of water supply in the village as per the requirement of the village.
- p) Comprehensive Maintenance for 5 years and Performance guarantees for the rated delivery / discharge of water as per standard test condition.
- q) All civil structures and site clearances for setting up of the complete job are to be obtained before installation.
- r) All structural drawings to be got approved from OREDA/ any other competent authority, if necessary at any time.
- s) While implementing Solar energy based dual pump piped water supply scheme in the village the physical condition of the area on shades / water logging during rain should be taken into consideration.
- u) There should not be any damage what so ever in the village due to setting up of the solar dual hand pump and later there is no leakage of any water connection of the said project the in the village.
- v) While cabling the array care must be taken such that no loose / open cables lie anywhere related to the supply / installations.

w) Adequate training has to be provided to the persons to be designated by OREDA/ pump users in maintenance and upkeep of the installed system. The installed and commissioned systems are to be handed over to the Village Committee / respective authorised officer. The bidder must also provide a detailed operation and maintenance manual specific to the installed systems.

x) Before execution of the supply / installation the yield test of the selected tube well shall be carried out by the agency to ensure the sustainability of the system.

y) Care should be taken to install the OHT at the highest point nearer to the habitation while the stand posts shall be installed as close to the households as possible. In case length of pipe exceeds the assigned length in the tender payment for the extra work shall be made as per current Schedule of Rate by the User Department.

2. Eligibility Criteria

In order to be eligible to participate in the tender, the bidder must fulfill the following eligibility criteria. Any discrepancy or deviation from the same shall make the bidder ineligible for participating in the tender and such tender documents shall be rejected.

- a) The bidder must be a company registered under the Indian Companies Act 1956 or a firm registered under GST.
- b) And the bidder must be a manufacturer of any component of solar pumps or a system integrator. A copy of the registration certificate (DIC, NSIC, MSME, Register of Companies, etc) to that effect is to be attached. No entity such as dealer, supplier, consortium, associates of any category is allowed.
- c) And the Bidder must have Test Certificate issued in the name of the bidder only for the tendered Model of Solar PV Water Pumping System (675 wp submersible pump) from IEC, NABL. MNRE authorized valid testing center. The pump must fit into min bore well 4 diameter.
- d) And the bidder's company/ firm must have manufactured, tested and commissioned minimum 500 nos of solar PV pumps in the country in last 5 years. Out of aforementioned criteria at least 50 pumps should be in the dual pump for drinking water category. The Copy of the certificates only and no other documents from the authorized / designated public officer should be furnished as per the following table.

Sl no	Name of govt /public user agency	Name of scheme / year	No of solar pumps installed	No of dual pumps	Certificates attached

- e) And the bidder company must have **annual turnover** of Rs.20 crore in last three years (2014-15 to 2016-17).A Chartered Accountant certificate to that effect is to be attached.
- f) Max. of 10% of the tendered quantity shall be considered for local registered small and medium entrepreneurs **who are already enlisted with OREDA for such work only as per the the L1 price to be arrived at.** No new local firm is allowed for this tender.
- g) The firm is not under debarred / blacklisted / defaulted by any Govt. Dept, agency, PSUs / institution / agencies / autonomous organisations during the period of tender. A self-certificate by an authorized person of the bidder's company/firm is to be attached.

3. INSTRUCTIONS TO BIDDERS

Intending bidders are requested to carefully study the instructions contained hereunder before preparing their bid documents for submission.

1. A Bidder shall submit a single offer-bid only. The bidders shall be responsible for properly uploading the relevant documents in the e-tender portal in the specified location and Tender Inviting Authority shall not be held liable for errors or omissions done while uploading the online bid.
2. Bidders must submit their bids for all items as stated in this bid document above.
3. Demand Drafts towards cost of document and EMD should be submitted in a separate envelop placed inside the envelope containing the technical bid.
4. Bids must be submitted in English language only.
5. Incomplete, telegraphic or conditional bids shall not be accepted.
6. Prices quoted must be firm and fixed. No price variation / escalation shall be allowed during process of completion of the project or for a period of one financial year whichever is earlier.
7. The bidders must sign at the bottom of each page of the bid documents at the time of submission in token of unconditional acceptance of the departmental terms and conditions, technical specifications etc.
8. Valid tax return submission document must be submitted along with the bid. **All rules and circulars of Finance Department, Govt of Odisha issued from time to time will be applicable during project period from issue of tender to the completion of 5 years CMC period.**
9. Deviations in terms and conditions, Specification of material, Inspection clause etc. will not be accepted under any condition.
10. The bidder shall submit copies of documents defining the constitution or legal status, place of registration and principle place of business of company or firm.
11. The bidder shall furnish a brief write up backed with adequate data, explaining capacity and experience (both technical and commercial) for the manufacture and supply of the required systems, equipments within the specified time of completion after meeting all their commitments.

12. Earnest money as specified in bid may be deposited in cash at OREDA cash counter or in shape of Demand Draft drawn in favour of Chief Executive, OREDA payable at Bhubaneswar from any nationalized bank. Bids without E.M.D will not be accepted unless exempt.
13. Bids received late due to postal delay or otherwise will not be considered.
14. The bidders are required to furnish their offers in the price bid both in words & figures online only. Any correction shall liable the document to be rejected. In case of any conflict between figures and words, the latter shall prevail.
15. Since timely execution of supply / installations is of paramount importance, requests for extension of time shall not be ordinarily entertained.
16. Canvassing in any manner shall not be entertained and will be viewed seriously leading to rejection of the bid.
17. Certificate to the effect that the systems to be supplied are indigenous & not fully imported must be furnished.
18. Power of attorney to sign the agreement on behalf of bidders & partnership deed articles, if any, should be enclosed along with original bid documents.
19. Notice inviting Tender, bid documents, prescribed Technical bid, price bid, terms & conditions will form the part of the tender.
20. All pages of the bid documents must be signed & sealed by the authorized person on behalf of the bidders.
21. Bids will be accepted & will be opened as per information mentioned in the notice-inviting tender. No receipt against submission of bid shall be issued by OREDA.
- 22. A pre bid meeting will be convened on ----- in the conference hall of OREDA. After discussion, deliberation and written statement / suggestions of the representative, the final tender document revised and approved has been uploaded on the website replacing the previous one.**
23. Any clarification on the technical specification and commercial terms and conditions may be clarified in writing from OREDA.
24. Deviation of any commercial terms and condition and technical specification shall not be entertained under any circumstances
25. Bidders may in their own interest visit the sites in order to develop a clear understanding of the logistics and other features of the sites before submitting bids and under taking may be attached in the tender document. OREDA will not be responsible for any incidental or consequential losses of the firms while execution and till expiry of the period of maintenance.

26. All the bidders shall essentially indicate the break-up of prices as shown in Price bid.

27. If qualified, the bidder must open a local office at Bhubaneswar before commencement of the supply / installation for coordination of all jobs and service centres fully equipped with technical person and spare parts at cluster level in the district where solar pumps installed. Such facility must have proper mailing address with contact person detail from time to time for all documents. **All supply / installation orders shall be placed with the state local registered office of the qualified empanelled bidders having valid Odisha GST.**

28. On award of contract the qualified bidder shall be termed as executing agency.

29. Opening of the bids:

The procedure of opening of the bid shall be as under

- i) The technical bid opening is ONLINE. The date of opening of the technical bid is only published in advanced. The date of opening of the price bid will be decided after verification of those bidders who qualify in the technical bid evaluation and will be informed in advance.
- ii) The online opening of the technical bid and the price bid shall be done by the Chief Executive / or his authorised representative as per bid schedule. The prospective bidders can access to the online opening by logging in to the e-tender portal with the registered digital signature. Bidders / its authorised representative may not come to this office of OREDA for the opening of the technical or price bids.
- iii) In the event of the specified date for opening of the bids being declared holiday, the bid shall be opened at the appointed time and venue on the next working day.
- iv) In the event of the bid and claims in the online documents are materially missing or of substantial error or want of required qualifications, shall stand disqualified and rejected.

30. Evaluation of Technical Bids

- i) The documents submitted as technical bids shall be scrutinized by a bid evaluation committee duly appointed.
- ii) The bid evaluation committee may also verify the veracity of claims in respect of the known performances of the items offered, the experience and reputation of bidder in the field, the financial solvency. The Tender Inviting Authority, if required reserves the right to inspect the facility of the bidder for verification of information furnished in the bid.

iii) The decisions of the bid evaluation committee on whether the bidders are responsive or non responsive.

iv) The verification of the items shall be conducted by the Technical Committee in which the external experts from the user institutions / funding agency.

v) The decision of the technical committee will be published

Technical Evaluation and Scoring Patterns

SI	Parameters	Max Points	Evaluation Criteria
A	Organizational Capability-	75	
1	Should have min 5 years experience in solar PV / any pump manufacturing or EPC in Govt sector or PSU	15	5 years - 5 Marks Beyond 5 years - for each year 2 marks up to maximum 10 marks
2	Quality Certification	10	- ISO9001 – 5 Marks - ISO14000-5 Marks
3	Experience of installation of min 500 pumps (AC/DC/Surface/ submersible) in Govt sector or PSU.	30	500 pumps-10 Marks Beyond 500 For every 200 pumps 5 marks up to maximum 20 marks
4	Should have Annual turnover @ Rs.15.00 cr for last 3 years	20	15 cr for 3 years -5 marks Beyond 15 cr for every 5 cr every year 5 marks max 15 marks
B	Technical Capability	25	
1	Pump must have IEC or MNRE or NABL certificate with 500 Wp module for BLDC /PMDC motor with validity period	10	
2	Pump must be easy to install in 4 bore	5	
3	Pump must have proven track record of 5 years of minimum maintenance in Odisha or in the country.	10	

1. Bidders have to score 70% for successful in Technical evaluation fulfilling all the minimum criteria up to 10 bidders as per the scoring order.
2. In case of all 10 bidders not reaching 70% the score of higher order up to 10 bidders shall be qualified.

31. Price bid opening & evaluation

i) The opening of the price bid shall be done online by the Tender Inviting Authority or the authorized representative and only the price bids in the proper format of the those firms qualified in the evaluation of the technical bids shall be opened.

ii) The cost indicated in the financial bid shall be deemed as final and reflecting the total cost of supply and services. Omission, if any, in costing any item shall not entitle the firm to be compensated and the liability to fulfil the obligation as per the terms and condition within the total quoted price shall be that of the bidder.

32. Acceptance/ Rejection of the bid documents:

Chief Executive, OREDA reserves the right to reject or accept any bid or annul the bidding process at any time prior to award of contract, without having prejudice of incurring any liability to the affected bidders or any obligation to inform the bidders.

Sd/dt-10.5.2018

Chief Executive

I/we have carefully read & understood the above terms & conditions of the bid & agree to abide by them.

Signature and Seal of bidder

4. COMMERCIAL TERMS & CONDITIONS

The Chief Executive, OREDA shall award the contract to the successful bidders whose bids shall be qualified after evaluation in terms of the responsiveness and lowest rate determined on the basis of price bids. On receipt of the awarded work the same should be submitted duly signed by the authorised person on each page within 7 days duly endorsed by the respective EE, RWSS /authorised Officer of Division and OREDA RE Cell Officials as acceptance of the terms and conditions. In case of non submission of the same duly complied the said award shall stand cancelled.

4.1 **Rate:**

The offer should indicate the unit cost of the system, Installation & Commissioning charges, CMC Charges and taxes & duties separately (Annexure I, J). The unit cost must be inclusive of packing, forwarding, loading & unloading charges, cost of insurance and transportation FOR destination in the entire state where the system will be installed as per the supply / installation order.

4.2 **Tax & Duties etc:**

All taxes and duties applicable (revised at the time of delivery of materials) from time to time will be paid. All statutory deductions applicable for the period of the project shall be effected.

4.3. **Earnest Money Deposit:**

4.3.1 Earnest money deposit Rs.20.00 lakh as specified in the Table above is required to be deposited along with the bid without which the bid will not be accepted. No interest will be payable for the EMD amount under any circumstances.

4.3.2 Earnest money shall be submitted in shape of a Demand Draft in favour of Chief Executive, OREDA or BG valid for 120 days(format enclosed) from any Nationalised Bank Payable at Bhubaneswar and the proof of deposits should be attached to the bid. E.M.D would be refunded to the unsuccessful Bidders after finalization of the bid without any interest.

4.3.3 E. M. D would be forfeited in case of non- compliance of the purchase order by the successful bidders. EMD submitted shall be returned to successful bidders only after Security cum Performance Bank Guarantee of at least 5 years is deposited.

4.3.4 In case of claim for exemption from deposit of Earnest money sufficient proof in support of claim for exemption of EMD as prescribed in Govt. of India Notification is to be attached with the bid. All benefits as per the Govt of Odisha policies will be applicable for local eligible firms only.

4.4 Security Deposit/ Performance Guarantee Fees:

The successful bidders must deposit **Two numbers of bank guarantees** (Annexure-H) towards Security cum Performance Guarantee fees with the Chief Executive, OREDA, Bhubaneswar along with bills, challans and all other documents as per payment clause before processing of payment as follows

- i) 9 % of the ordered value in shape of irrevocable Bank Guarantees with **5 years validity** from the date of supply, installation and commissioning till the completion of respective warranty and CMC period of the composite system.
- ii) 1 % of the ordered value in shape of irrevocable Bank Guarantees with **10 years validity** from the date of supply, installation and commissioning till the completion of respective warranty period of the module.

The said deposit would be forfeited, if the supplies are not made and performances are not as per the Terms & Conditions of the purchase order. The first security deposit amount will be refunded after the expiry of the Warranty period and CMC period of the systems i.e 5 years after commissioning of each system, subject to satisfactory execution / performance of the systems. The 2nd PBG will be refunded after the expiry of 10 years i.e module performance guarantee after successful performances.

All benefits as per the State Govt policies will be applicable for local eligible firms only.

4.5 Programme Execution Schedule:

The programme of execution of the supply, installation and commissioning shall be carried out as per the schedule given in the supply / installation order subject to issue of water yield test / layout documents by the respective Nodal Officer of RWSS in phased manner. In case all yield test report are available at the time of issue of supply / installation order the entire job has to be completed within maximum 3 months of sites clearance reports from RWS&S / Authorised Officer / OREDA

Execution of supply / installation shall be carried out in an approved manner as outlined in the technical specification or where not outlined, in accordance with the relevant Indian Standard Specification, to the reasonable satisfaction of the Authorized OREDA Officer.

4.5.1 Upon intimation about commissioning of the systems by the executing firm a joint inspection will be carried out by the representatives of the executing firm, OREDA and other officers from Govt of Odisha / Govt. of India.

4.5.2 The issuance of a JCC shall, in no way relieve the executing firm of its responsibility for satisfactory operation of the solar submersible pump systems.

4.6 Validity of offer:

The price bid offer (Annexure-H,I) must be kept valid minimum for a period of one year from the date of opening of the technical bid. No escalation clause except the admissible tax component under the period of consideration would be accepted, if any. The validity can be mutually extended for a suitable period, if situation demands, with all terms and conditions as per the tender.

If at any time during the said period the empanelled bidders enhance schedule or reduce the price of such offered items or sells such items to any other Govt Organization at a price lower than the price chargeable under the contract or include additional schedule of supply, the supplier shall forthwith notify such modification to OREDA.

Any qualified firm violating to aforesaid conditions whenever noticed shall be delisted from the panel.

4.7 Tax return:

The bidders must submit attested copy of valid up to date tax clearance / tax return certificate along with the bid. The bid would not be considered without this document.

The original certificate would be produced at the time of opening of the bid, or, before issue of purchase order, if required.

4.8 Warranty:

The Supplier warrants that the Goods(as per the test report issued by authorized test centre) supplied under this Contract are new, unused, of the most recent or current models and incorporate all recent improvements in design and materials unless provided otherwise in the Contract. The Supplier further warrants that the Goods supplied under this Contract shall have no defect arising from design, materials or workmanship (except when the design and/or is required by the Purchaser's Specifications) or from any act or omission of the Supplier, that may develop under normal use of the supplied Goods in conditions prevailing in the country of final destination.

This warranty shall remain valid for 60(sixty) months after the Goods or any portion thereof as the case may be, have been delivered to and commissioned and accepted at the final destination indicated in the Contract.

The Purchaser shall promptly notify the Supplier in writing of any claims arising under this warranty. Upon receipt of such notice, the Supplier shall repair or replace the defective Goods or parts thereof, without cost to the Purchaser other than, where applicable, the cost of inland delivery of the repaired or replaced Goods or parts from the port of entry to the final destination.

If the Supplier, having been notified, fails to remedy the defect(s), the Purchaser may proceed to take such remedial action as may be necessary, at the Supplier's risk and expense and without prejudice to any other rights which the Purchaser may have against the Supplier under the Contract.

4.9 Penalty and termination of contract:

The systems shall be supplied, installed and commissioned within the scheduled time as mentioned in the supply / installation order. If the supplier fails to adhere to the schedule, OREDA shall without prejudice to its other remedies under the contract deduct from the contract price as liquidated damages a sum equivalent to 1% of the delivery price of the delayed goods or unperformed services for each week of delay until actual delivery or installation/commissioning up to a maximum deduction of 5% of the contract price for delayed goods or installation and commissioning. Once the maximum is reached (i.e 5 weeks of delay) OREDA may consider termination of the contract and forfeit the security deposit without prejudice to the other remedies of the contract.

If at any time during the performance of the Contract, the Supplier or its sub-contractors should encounter conditions impeding timely delivery of the Goods and performance of the Services, the Supplier shall promptly notify the Purchaser in writing of the fact of the delay, its likely duration and its cause(s). As soon as practicable after receipt of the Supplier's notice, the Purchaser shall evaluate the situation and may at its discretion extend the Supplier's time for performance, with or without liquidated damages, in which case the extension shall be ratified by the parties by amendment of the Contract.

A delay by the supplier in the performance of its delivery obligations shall render the supplier liable to the imposition of liquidated damages pursuant, unless an extension of time is agreed upon without the application of liquidated damages.

4.10 Termination for Default

The Purchaser may, without prejudice to any other remedy for breach of contract, by written notice of default sent to the Supplier, terminate the Contract in whole or in part:

- 4.10.1 if the Supplier fails to deliver any or all of the Goods within the period(s) specified in the Contract, or within any extension thereof granted by the Purchaser; or

- 4.10.2 if the Supplier fails to perform any other obligation(s) under the Contract.
- 4.10.3 If the supplier, in the judgement of the purchaser, has engaged in corrupt or fraudulent practices in competing for or in executing the contract.

For the purpose of this clause:

“Corrupt practice” means the offering, giving, receiving, or soliciting of anything of value to influence the action of a public official in the procurement process or in contract execution. “fraudulent practice” means a misrepresentation of facts in order to influence a procurement process or the execution of a contract to the detriment of the borrower, and includes collusive practice among bidders (prior to or after bid submission) designed to establish bid prices at artificial non-competitive levels and to deprive the borrower of the benefits of free and open competition.

In the event the Purchaser terminates the Contract in whole or in part, the Purchaser may procure, upon such terms and in such manner as it deems appropriate, Goods or services similar to those undelivered, and the Supplier shall be liable to the Purchaser for any excess costs for such similar Goods or services. However, the Supplier shall continue the performance of the Contract to the extent not terminated.

4.11 Inspection:

Pre delivery inspection of major components may be carried out by a team of designated officials of OREDA, any other department as may be considered appropriate at the factory site of the vendor / manufacturer. Before despatch of consignment intimation shall be given sufficiently ahead so that no delay occurs for deputing officials and inspection at the premises / test site.

4.11.1 The rest of the tests and inspections shall be made at the place of delivery.

Officers authorized by OREDA shall be entitled at all reasonable time to inspect and supervise and test during erection and commissioning. Such inspection will not relieve the executing firm of their obligation in the contract. The water output as per technical specification has to be guaranteed without any controversies of variation of water table.

4.11.2 OREDA shall have the right to have the tests carried out at its own cost by an independent agency at any point of time.

4.12 Payment:

Payment will be made in instalment of solar water pumping system installed out of the total supply / installation order issued against the respective in the following manner

Total value of systems with full taxes / duties (excluding CMC charges) will be made after commissioning of the project. The check list of documents to be submitted along with the bills and Security cum Performance Bank Guarantee for release will be as per the purchase order issued.

For processing of the payment the indicative documents are to be submitted like (Annexure-B,C,D,E,F) all technical detail of the installed system, inspection and testing report, location map of the System, GPS based photograph wherever available of the hand pump, OH tank and solar PV array, System handing over report, Warranty certificate, Joint commissioning certificate or any other documents as may be required.

4.13 Allocation of award & Execution:

All supply / installation orders shall be placed with the state local registered office of the qualified empanelled bidders having valid Odisha tax registration.

Minimum 30 % total allocation of work will be awarded to the qualified bidder as per the price bid evaluated(scoring) responsive bid. In case of equal rate being quoted by more than one bidder, the work to be executed shall be equally divided among them @20 % to each of the firm to the extent possible.

In view of large geographical spread and expeditious completion of the project, it is imperative that there shall be multiple vendors subject to their acceptance to the L1 price discovered in the tender for the bidders other than the local category. Successful bidders willing to accept the L1 price may be duly empanelled and arranged in order of their quoted price up to 10th bidder.

For local vendors empanelled already with OREDA 10 % of the overall allotment will be preferably on the basis of performance of the trial order agreed to match the L1 price.

4.14 Comprehensive Maintenance Contract:

CMC amount in the price offer must be min 5% (@1% each year) of the total of supply, installation & commissioning. The qualification of the L1 bidder will be decided based on the CMC bench mark. CMC will be applicable during the period of the warranty period of 5 years. The bidder must enter into a Comprehensive maintenance contract for the specified period at the time of execution of the order. Offer without such CMC shall not be considered (sample format of CMC enclosed at Annexure). The scope of CMC must cover supply of all spare parts, services and performance reports during the contract in force. Order shall be placed on bidders who agree to offer such CMC. The payment of annual maintenance charges under the Comprehensive Maintenance Contract shall depend upon the functionality of the system duly certified by the concerned Authorised officials of OREDA. Upon receipt of such certificates CMC amount as applicable shall be paid at the end of 1st, 2nd, 3rd, 4th and 5th years.

4.15 Limitation of Liability:

OREDA, will, in no case be responsible for any accident fatal or non-fatal, caused to any worker or outsider in course of transport or execution of supply / installation. All safety measures as per prevailing norms should be adopted. All the expenditure including treatment or compensation will be entirely borne by the Executants. The Executants shall also be responsible for any claims of the workers including PF, Gratuity, ESI & other legal obligations. The executants shall take all steps towards the security compliances.

4.16 Force Majeure:

In no event shall either Party have any liability for failure to comply with this Agreement, if such failure results directly from the occurrence of any contingency beyond the reasonable control of the Party, including, without limitation, strike or other labor disturbance, riot, major power failure, war, natural calamities including but not limited to floods, earthquakes, fire, volcanic eruptions, epidemics, National Emergency, interference by any government or governmental agency, embargo, seizure, or enactment or abolition of any law, statute, ordinance, rule, or regulation (each a " Force Majeure Event"). In the event that either Party is unable to perform any of its obligations under this Agreement because of a Force Majeure Event, the Party who has been so affected shall as soon as may be, after coming to know of the Force Majeure Event, inform the other Party and shall take reasonable steps to resume performance as soon as may be after the cessation of the Force Majeure Event. If the period of nonperformance due to a Force Majeure Event exceeds thirty (30) days, the Party whose ability to perform has been so affected may, by giving written notice, terminate this Agreement.

4.17 Dispute:

For adjudication of any dispute between OREDA and the bidders arising in this case, reference can be made to any Law courts under the jurisdiction of Odisha High court only. The Chief Executive, OREDA reserves the right to accept or reject any or all bids without assigning any reason thereof.

Sd/dt-10.5.2018

Chief Executive

I/We have carefully read and understood the above terms and conditions of the bid and agree to abide by them.

Signature of the bidder with Seal

ANNEXURE-A**TECHNICAL SPECIFICATION****DEFINITION : Solar energy based dual pump piped water supply scheme**

includes complete solution for supply, installation, commissioning and comprehensive maintenance contract (CMC) for 5 years. The solar dual pump should consist arrangement of installation of Solar photovoltaic submersible pump in addition to the hand pump in the same bore well/Tube well.

System should consist Solar Panels, Submersible pump, electronics, module mounting structure, hot dip galvanized Tank Tower Structure (3m ht), 5,000 liters LDPE water storage tank, common Stand Post, distribution pipe line.

1. PV ARRAY

The SPV water pumping system should be operated with a PV array capacity in the range of 675 Wp, measured under Standard Test Conditions (STC). Sufficient number of modules in series and parallel could be used to obtain the required PV array power output. The power output of individual PV modules used in the PV array, under STC, should be a minimum of 225 Watts peak, with adequate provision for measurement tolerances. Use of PV modules with higher power output is preferred.

Indigenously produced PV module (s) containing mono/ multi crystalline silicon solar cells should be used in the PV array for the SPV Water Pumping systems.

- Modules supplied with the SPV water pumping systems should have certificate as per IEC 61215 specifications or equivalent National or International/ Standards.
- Modules must qualify to IEC 61730 Part I and II for safety qualification testing.
- The efficiency of the PV modules should be minimum 14% and fill factor should be more than 70%.
- The terminal box on the module should have a provision for “Opening” for replacing the cable, if required.
- There should be a Name Plate fixed inside the module which will give:
 - a. Name of the Manufacturer or Distinctive Logo.
 - b. Model Number
 - c. Serial Number
 - d. Year of manufacture

1. Mono/Multi-crystalline Solar Panels Capacity – 675 wp
2. Adequate anti-theft fittings need to be provided for each panel.

2. MOUNTING STRUCTURES, TRACKING SYSTEM.

To enhance the performance of SPV water pumping systems, it is desirable to use a tracking system. Manual, passive and auto tracking are permitted. The PV modules will be mounted on metallic structures of adequate strength and appropriate design,

which can withstand load of modules and high wind velocities up to 150 km per hour. The support structure used in the pumping system will be hot dip galvanized iron (G.I).

Facilities to be provided in the structure: Three times manual tracking in a day

The G.I. structures for mounting the Solar panels could be so designed, that these can be manually/ auto adjusted for optimal tilt throughout the year. A simple provision is to be provided so that the panel can be manually adjusted three times a day (East-West) to face the sun optimally. This adjustment could be done in the early morning, noon time and afternoon to increase the total input solar radiation on the solar panel surface substantially. This provision helps the motor pump set to start early in the morning and function efficiently till late in the afternoon, thereby increasing the total output of the pumping system.

The “Mounting Structure” should have the following features:

- The modules support structure shall be mild steel, hot dipped galvanized (120 micron) iron for holding the PV modules. The size of angle iron should not be less than 50x50x5 mm.
- Each panel frame structure shall be so fabricated as to be grouted on ground of min 2.5 meter above ground level on a single galvanized iron pole of 100 mm dia with 4.8 mm thickness. It will withstand severe cyclone/ storm with the speed of 150 Km/Hr.

Each panel frame shall be complete with a weatherproof junction box as per the relevant BIS specifications, where the module terminals shall be interconnected and output taken.

- All nuts and bolts should be made of very good quality and should be corrosion resistant.
- The structure should be designed to allow easy replacement of any module.
- The array structure shall be so designed that it will occupy minimum space without sacrificing the output from the SPV panels.

3. ELECTRONICS AND PROTECTIONS

- Maximum Power Point Tracker (**MPPT**) should be included to optimally use the Solar panel and maximize the water discharge.
- Inverter could be used, if required, to operate an A.C. Pump. The inverter must have IP 54 protection or must be housed in a cabinet having at least IP54 protection.
- Controller for BLDC motor driven pumps, if required be used. The controller must have **IP 54** protection or must be housed in a cabinet having at least IP 54 protection.
- Adequate protections should be incorporated against dry operation of motor pump set, lightning, hails and storms.

- Full protection against open circuit, accidental short circuit and reverse polarity should be provided.

4. ON/OFF SWITCH

A good reliable switch suitable for DC use is to be provided. Sufficient length of cable should be provided for inter-connection of the PV array, Controller / Inverter and the motor pump set.

5. WARRANTY

The PV Modules must be warranted for output wattage, which should not be less than 90% at the end of 10 years and 80% at the end of 25 years. The whole system including submersible/ surface pumps shall be warranted for 5 years. Required Spares for trouble free operation during the Warrantee period should be provided along with the system.

6. OPERATION AND MAINTENANCE MANUAL

An Operation and Maintenance Manual, in English and the local language, should be provided with the solar PV pumping system. The Manual should have information about solar energy, photovoltaic, modules, DC motor pump set, tracking system, mounting structures, electronics and switches. It should also have clear instructions about mounting of PV module, DO's and DONT's and on regular maintenance and Trouble Shooting of the pumping system. Name and address of the person or Centre to be contacted in case of failure or complaint should also be provided.

B. Solar Submersible Pump

- Light weight stainless steel helical rotor / equivalent submersible pump with MPPT pump controller with suitable indication and control, Permanent magnet brushless motor.
- Pump type – 1 HP, Positive displacement, Helical rotor /equivalent
- Rated rpm – 500 to 3600
- Rated voltage – 30 to 300V
- Rated current – 10 amp (max)
- Built-in features –
 - a. Outer dia should not be more than 96 mm,
 - b. Out let of the pump should be 25- 32mm
 - c. Dry run protection
- Over and under voltage protection
 - a. Overload protection
 - b. Temperature Protection
- ISI mark cable 3 core x 2.5 sq.mm.

Auto Water Level Controller without Battery :-

Automatic OFF/ON for controlling water level in the tank.

Cable:-

- 3 core x 2.5 sq.mm cable as per IS 694- 70 meters.
- PVC Pipe ½ inch for covering cable for concealed connection – 10 mtrs.
- Cable clips 20 Nos.

Water Supply System

The depth of submersible Pump shall be max 60 mtrs or as per the depth of the bore with independent riser pipe. HDPE / CPVC pipe as per IS of 63 mm size shall be used from over head tank to stand post below ground level connection at a depth of minimum 60cm of required length with provision of 1/8 ferrule connection should be provided by the supplier. Only GI pipe of 50/32/25 mm size shall be used for over ground connection such as inlet, outlet and over flow connection of OHT and to distribution line connected to four mouth hot dip galvanised Common stand post with stainless steel self closing (304 grades) taps at a height 800mm. After testing of the pipe distributions and stand posts the trenches to be filled up with excavated earth up to a depth of 30 cm watering and riming and making good to the damages of the road as per pre road condition (WBM/CC/Bituminous).

TECHNICAL SPECIFICATIONS**PART - B**

Supply, Installation of MS steel structure / LLDPE Rotational moulded polythene Cylindrical vertical water storage tank (Double Layer) 5000 liters capacity with ISI mark of IS : 12701:1996 Latest revision and completion of rising main distribution system ,etc. should be carried out as per the scheme details enclosed.

PART B : Technical Specifications of :

1. MS steel structure,
2. Rising main and distribution system
3. Civil Work.

1.MS Steel Structure :-

Design And drawings of the structure and foundation are enclosed

MS steel structure should be strong enough (main Columns and Base Frame for Over Head Tank be made out of minimum of 75 mm X 75 mm X 4.8 mm MS Sq. Tube) to hold minimum of 6 Tons of weight and should sustain to a minimum of 150 Km/ hr wind speed **for Model –II or G I** Structure should be strong enough (Main columns and base frame for Overhead Tank be made out of minimum of 91.5mm x 91.5mm x 4.5 mm square tube) to hold minimum of 7.5 tonnes of weight and cater to a minimum of 200 km/hr. wind speed. RCC foundation should be strong enough to hold weight of structure and water tank and the PV modules. Foundation bolt - M -16X700mm (length)-16 nos. 4 nos. for each concrete foundation **for Model-I.**

RCC foundation should be strong enough to hold weight of structure and 5000 Lit capacity water tank filled with water.

Height at which the tank kept is 3 mtr.

The structure should be hot dip galvanized (minimum thickness 80 microns and 120 microns in coastal area) Overhead tank structure should be erected on suitable solid foundation made of reinforced cement concrete as per the ground requirement.

All details of IS standards of MS Sq tubes , MS plates, Nut bolts and welded joints are as bellow ;

1. Indicates H.Y.S.D. BARS Fe 415 grade as per IS :1786
2. Grade of concrete M-20
3. Grade of PCC M-10(1:3:6)
4. Provide clear cover to main reinforcement
5. For Column- 40 mm
6. For Beams - 30 mm
7. Footing to be rest on hard strata
8. Lap length for column - 50 X DIA
9. All dimensions are in mm. unless otherwise specified
10. Minimum depth of foundation - 1.20 M
11. All high strength deformed bar (Fe 415) reinforcement shall be minimum yield strength mentioned in IS : 1786.
12. All welds are 4 mm continuous fillet unless otherwise noted.
13. All structural steel used for welded structures shall confirm to IS : 2062 Grade – A (Fe410 W A) except for MS plates over 16 mm thickness which shall confirm to IS : 2062 Grade - B(Fe 410 W B) unless otherwise noted.
14. Electrodes for Mild steel confirm to IS : 814 and IS : 815 (Latest)
15. Welding procedures are to be as per IS : 816 and IS 9595 (Latest)
16. Welding lengths wherever indicated are minimum required howerer full contact length to be welded in all cases unless noted otherwise.
17. All Bolts and Nuts shall confirm to IS : 1363 (Latest)
18. H.S.F.G. Bolts and Nuts shall confirm to IS : 3757 and IS : 6623 respectively.
19. Washers shall confirm to IS : 5369 -1975, IS : 5370-1969, IS : 5372-1975 or IS :5374-1975.
20. Bolts in direct tension shall be provided with the lock nuts or double coil spring washers.
21. All steel sections shall be thoroughly strengthened and wire brushed to ensure complete removal of rust and scale.
22. All dimensions refer to unfinished concrete dimensions unless shown or noted.
23. SBC of soil is assumed 200 Km/m²
24. Structural steel Fe 250 as per IS : 226.

Rising Main And Distribution System :

Rising main consist of GI pipe of 25 mm Dia. of IS : 1239 of suitable for the distance between hand pump special water chamber of dual pump system and HDPE water storage tank with vent pipe.

Distribution system consist of pipe line from water storage tank to common stand posts or individual tap connections .

Details are as bellow

Rising Main :

For Inlet of Tank Providing and laying ISI mark GI pipe of medium Class 25 mm Dia Including one end coupling for full length pipe. As per IS : 1239 /2004.

For Distribution - Providing And supplying and laying , in standard length ISI mark rigid

unplastisized PVC (6 kg/cm²) pipes 63 mm dia. suitable for potable water with solvent cement joint including couplers as per IS specification No.4985/1988.

Providing and construction two taps stand posts as per approved type and design (Drawing

shown in sheet No.- 4) with Excavation , 15 Cm thick bolder filling 15 cm thick PCC 1:3:6

bedding 20 mm thick PCC 1:2:4 concrete for platform of 1 Mtr Dia with side curb and bucket rest , 80mm Dia heavy duty GI pipe central post duly filled therein with CC 1:2:4 ,5

mtr long , 20 mm dia .medium GI pipe from point of tapping to stand post additional 20 mm

Dia GI pipe fixed vertically and providing and fixing two 15 mm Dia. self closing brass water

taps, 1 brass ferrule etc complete.

For Outlet of Tank providing and laying of ISI mark GI pipe of medium class 50 mm Dia.

Including complete with one end coupling for full length pipe As per IS : 1239/2004.

For Outlet of Tank supplying and installing gunmetal gate valve of size of 50 mm Dia.

Supplying and erecting heavy duty GI Union in position with necessary material for 25 mm

Dia, 40 mm Dia. and 50 mm Dia.

3.Civil Work :-

1.Civil work essentials for erection of overhead Tank Structure as per site conditions and soil formations

2. Civil work essentials for erection and skirting of stand post.

3. Civil work essentials for construction of hand pump platform.

4. LLDPE Rotational Moulded Cylindrical Vertical Water Storage Tank (Double Layer) 5000

liters capacity with ISI mark of IS : 12701:1996 conforming to all Latest revision.

Overall Diameter Range : 1800 to 2110 mm

Overall Height Range : 1800 to 2100 mm.

Minimum Internal Dia. Of man hole / Hand hole : 450 mm.

Minimum Wall And Bottom Thickness : 10.7 mm.

Minimum weight of Tank with out Lid : 180 Kg.

All other technical specifications should be as per IS specifications.

Minimum Reference drawing for model I with overhead Solar module

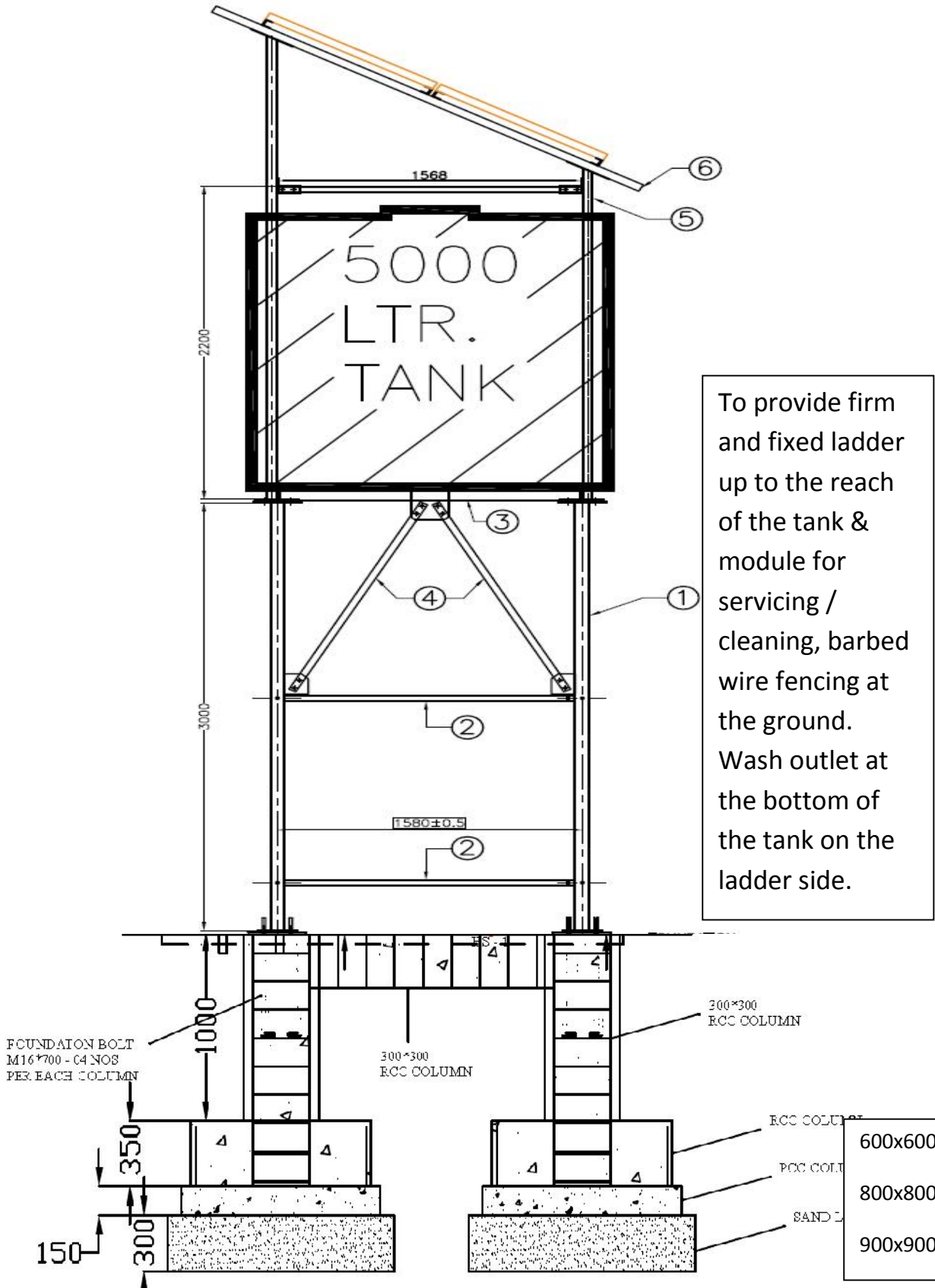

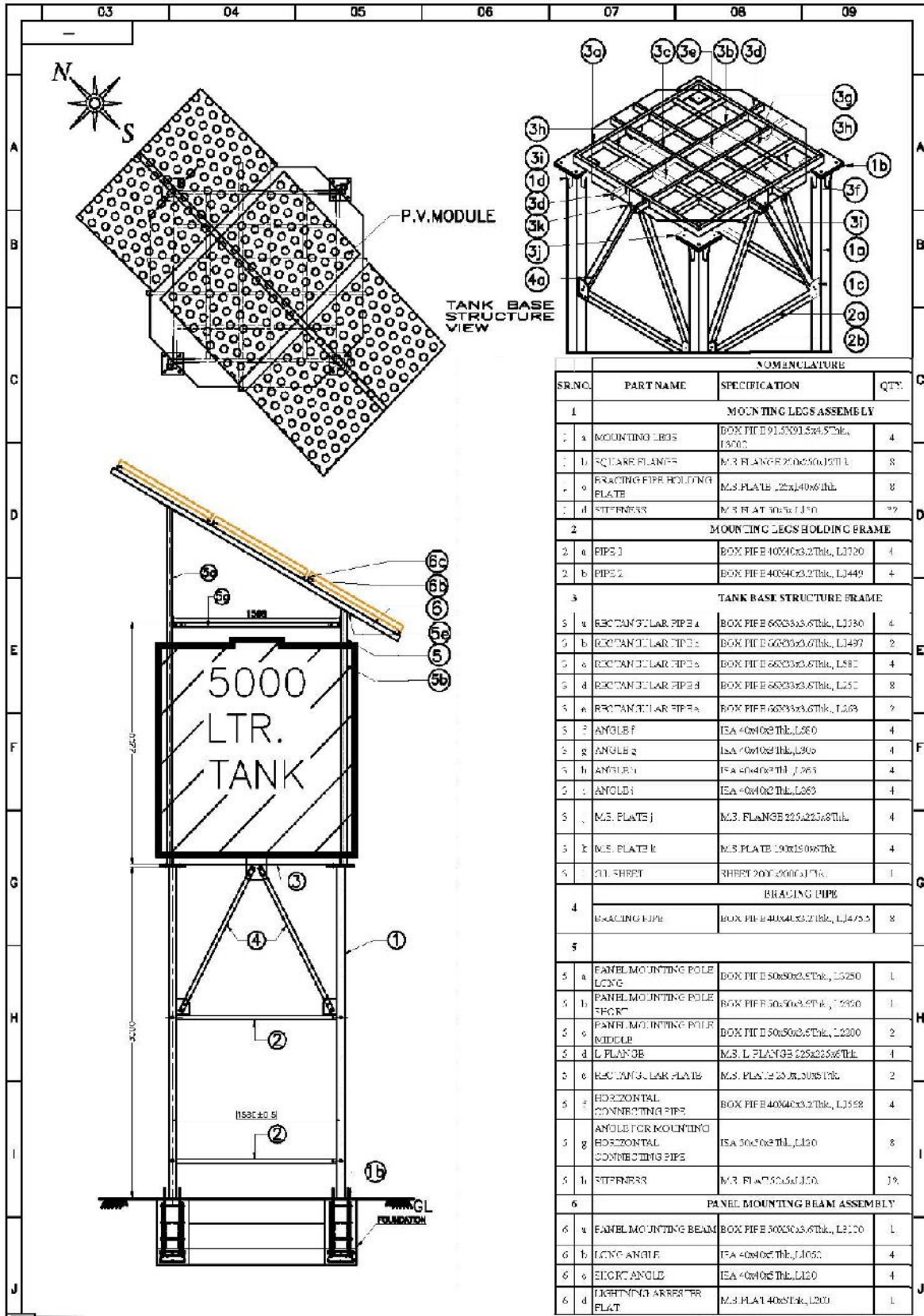

NOMENCLATURE			
SR.NO.	PART NAME	SPECIFICATION	QTY.
1 MOUNTING LEGS ASSEMBLY			
1 a	MOUNTING LEGS	BOX PIPE 91.5591.5x4.5Thk., L3002	4
1 b	SQUARE FLANGE	M.S. FLANGE 200x200x10T1	8
1 c	BRACING PIPE HOLDING PLATE	M.S. PLATE 120x140x6Thk.	8
1 d	STIFFNESS	M.S. PLATE 300x1150	2
2 MOUNTING LEGS HOLDING FRAME			
2 a	PIPE 1	BOX PIPE 400x400x2Thk., L3120	4
2 b	PIPE 2	BOX PIPE 400x400x2Thk., L3440	4
3 TANK BASE STRUCTURE FRAME			
3 a	RECTANGULAR PIPE 1	BOX PIPE 660x330x6Thk., L3380	4
3 b	RECTANGULAR PIPE 2	BOX PIPE 660x330x6Thk., L3497	2
3 c	RECTANGULAR PIPE 3	BOX PIPE 660x330x6Thk., L3812	4
3 d	RECTANGULAR PIPE 4	BOX PIPE 660x330x6Thk., L3812	8
3 e	RECTANGULAR PIPE 5	BOX PIPE 660x330x6Thk., L3812	2
3 f	ANGLE 1	ISA 40x100Thk., L380	4
3 g	ANGLE 2	ISA 40x100Thk., L380	4
3 h	ANGLE 3	ISA 40x100Thk., L380	4
3 i	ANGLE 4	ISA 40x100Thk., L380	4
3 j	M.S. PLATE J	M.S. FLANGE 225x225x8Thk.	4
3 k	M.S. PLATE K	M.S. PLATE 190x150x6Thk.	4
3 l	GL SHEET	SHEET 2000x2000x1Thk.	1
4 BRACING PIPE			
4	BRACING PIPE	BOX PIPE 400x400x2Thk., L3475.5	8
5 PANEL MOUNTING BEAM ASSEMBLY			
5 a	PANEL MOUNTING POLE LONG	BOX PIPE 500x500x6Thk., L5250	1
5 b	PANEL MOUNTING POLE SHORT	BOX PIPE 500x500x6Thk., L2950	1
5 c	PANEL MOUNTING POLE MIDDLE	BOX PIPE 500x500x6Thk., L3200	2
5 d	L FLANGE	M.S. L FLANGE 225x225x8Thk.	4
5 e	RECTANGULAR PLATE	M.S. PLATE 225x225x8Thk.	2
5 f	HORIZONTAL CONNECTING PIPE	BOX PIPE 400x400x2Thk., L3588	4
5 g	ANGLE FOR MOUNTING HORIZONTAL CONNECTING PIPE	ISA 50x50x8Thk., L120	8
5 h	STIFFNESS	M.S. PLATE 750x500x10	12
6 PANEL MOUNTING BEAM ASSEMBLY			
6 a	PANEL MOUNTING BEAM	BOX PIPE 500x500x6Thk., L3120	1
6 b	LONG ANGLE	ISA 40x100Thk., L3050	4
6 c	SHORT ANGLE	ISA 40x100Thk., L120	4
6 d	LIGHTNING ARRESTER PLAT	M.S. PLATE 400x140x120	1

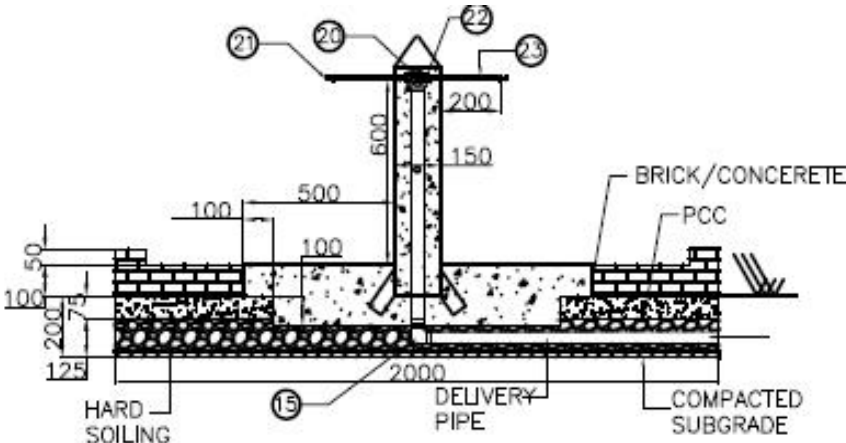

SC

STAND POST DETAIL VIEW

SHEET No. 2

Schematic Drawing of Special Water Chamber for Dual Pump System

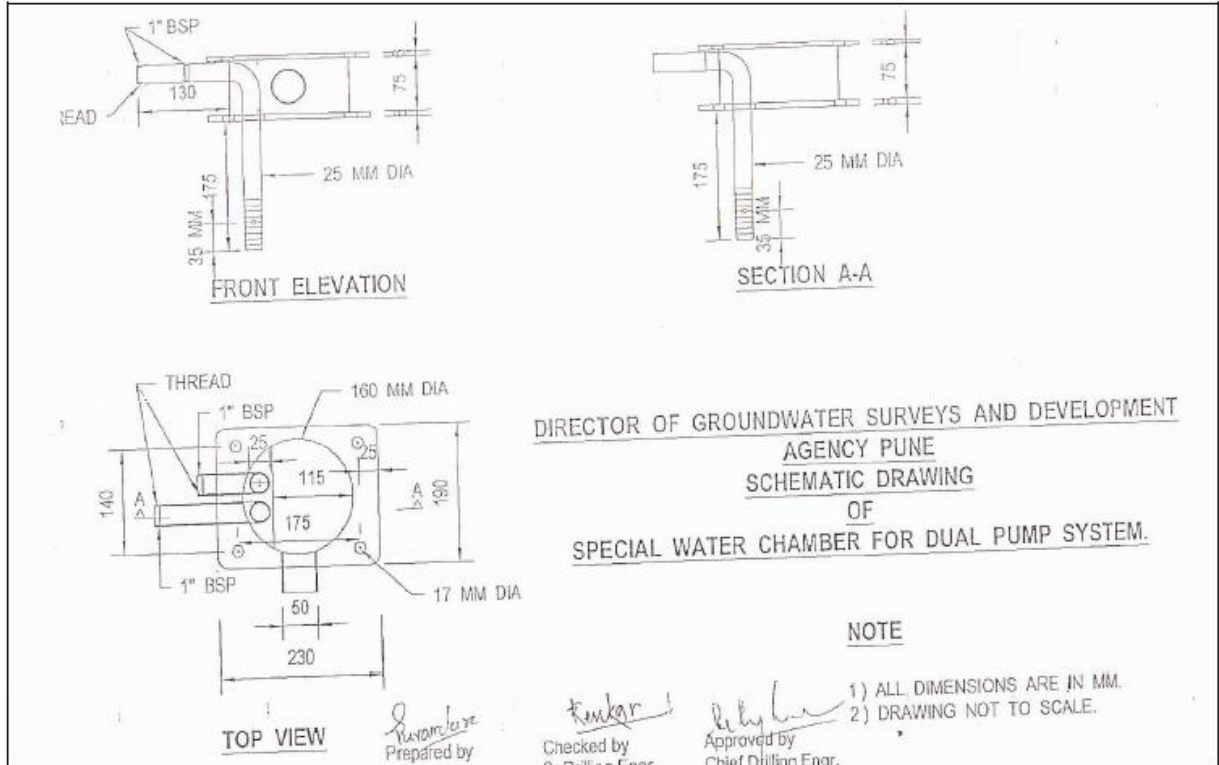

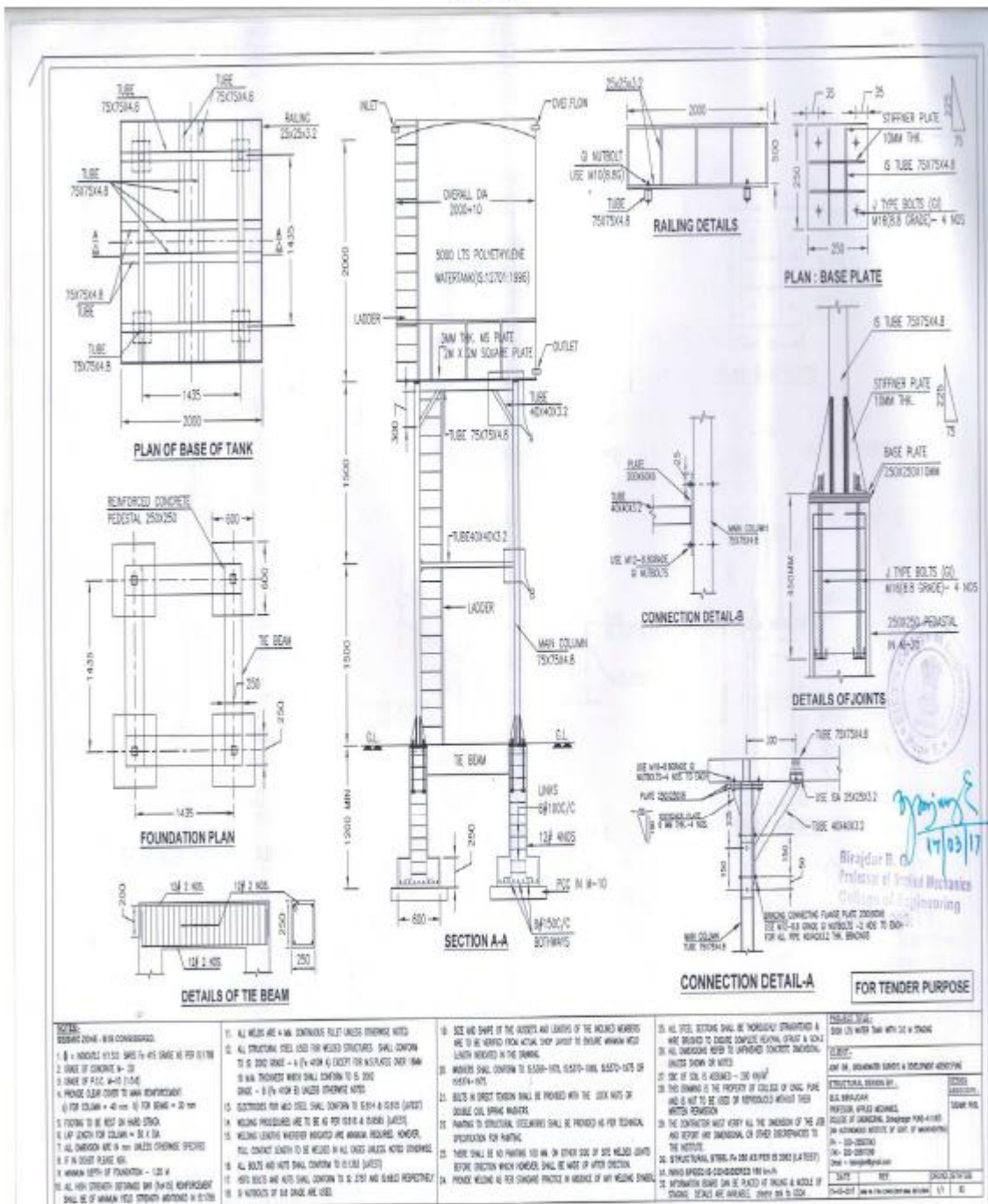

<p>NOTES: 1. ALL DIMENSIONS UNLESS OTHERWISE SPECIFIED ARE IN MILLIMETERS. 2. ALL DIMENSIONS ARE TO FACE UNLESS OTHERWISE SPECIFIED. 3. ALL DIMENSIONS ARE TO BE AS PER IS: 8000-1983. 4. ALL DIMENSIONS ARE TO BE AS PER IS: 8000-1983. 5. ALL DIMENSIONS ARE TO BE AS PER IS: 8000-1983. 6. ALL DIMENSIONS ARE TO BE AS PER IS: 8000-1983. 7. ALL DIMENSIONS ARE TO BE AS PER IS: 8000-1983. 8. ALL DIMENSIONS ARE TO BE AS PER IS: 8000-1983. 9. ALL DIMENSIONS ARE TO BE AS PER IS: 8000-1983. 10. ALL DIMENSIONS ARE TO BE AS PER IS: 8000-1983.</p>	<p>1. ALL WELDS ARE TO BE AS PER IS: 8000-1983. 2. ALL WELDS ARE TO BE AS PER IS: 8000-1983. 3. ALL WELDS ARE TO BE AS PER IS: 8000-1983. 4. ALL WELDS ARE TO BE AS PER IS: 8000-1983. 5. ALL WELDS ARE TO BE AS PER IS: 8000-1983. 6. ALL WELDS ARE TO BE AS PER IS: 8000-1983. 7. ALL WELDS ARE TO BE AS PER IS: 8000-1983. 8. ALL WELDS ARE TO BE AS PER IS: 8000-1983. 9. ALL WELDS ARE TO BE AS PER IS: 8000-1983. 10. ALL WELDS ARE TO BE AS PER IS: 8000-1983.</p>	<p>11. ALL WELDS ARE TO BE AS PER IS: 8000-1983. 12. ALL WELDS ARE TO BE AS PER IS: 8000-1983. 13. ALL WELDS ARE TO BE AS PER IS: 8000-1983. 14. ALL WELDS ARE TO BE AS PER IS: 8000-1983. 15. ALL WELDS ARE TO BE AS PER IS: 8000-1983. 16. ALL WELDS ARE TO BE AS PER IS: 8000-1983. 17. ALL WELDS ARE TO BE AS PER IS: 8000-1983. 18. ALL WELDS ARE TO BE AS PER IS: 8000-1983. 19. ALL WELDS ARE TO BE AS PER IS: 8000-1983. 20. ALL WELDS ARE TO BE AS PER IS: 8000-1983.</p>	<p>21. ALL WELDS ARE TO BE AS PER IS: 8000-1983. 22. ALL WELDS ARE TO BE AS PER IS: 8000-1983. 23. ALL WELDS ARE TO BE AS PER IS: 8000-1983. 24. ALL WELDS ARE TO BE AS PER IS: 8000-1983. 25. ALL WELDS ARE TO BE AS PER IS: 8000-1983. 26. ALL WELDS ARE TO BE AS PER IS: 8000-1983. 27. ALL WELDS ARE TO BE AS PER IS: 8000-1983. 28. ALL WELDS ARE TO BE AS PER IS: 8000-1983. 29. ALL WELDS ARE TO BE AS PER IS: 8000-1983. 30. ALL WELDS ARE TO BE AS PER IS: 8000-1983.</p>	<p>FOR TENDER PURPOSE</p>
--	--	---	---	----------------------------------

SHEET NO 4

Schematic Drawing of M S Structure for Solar Manual Tracking System

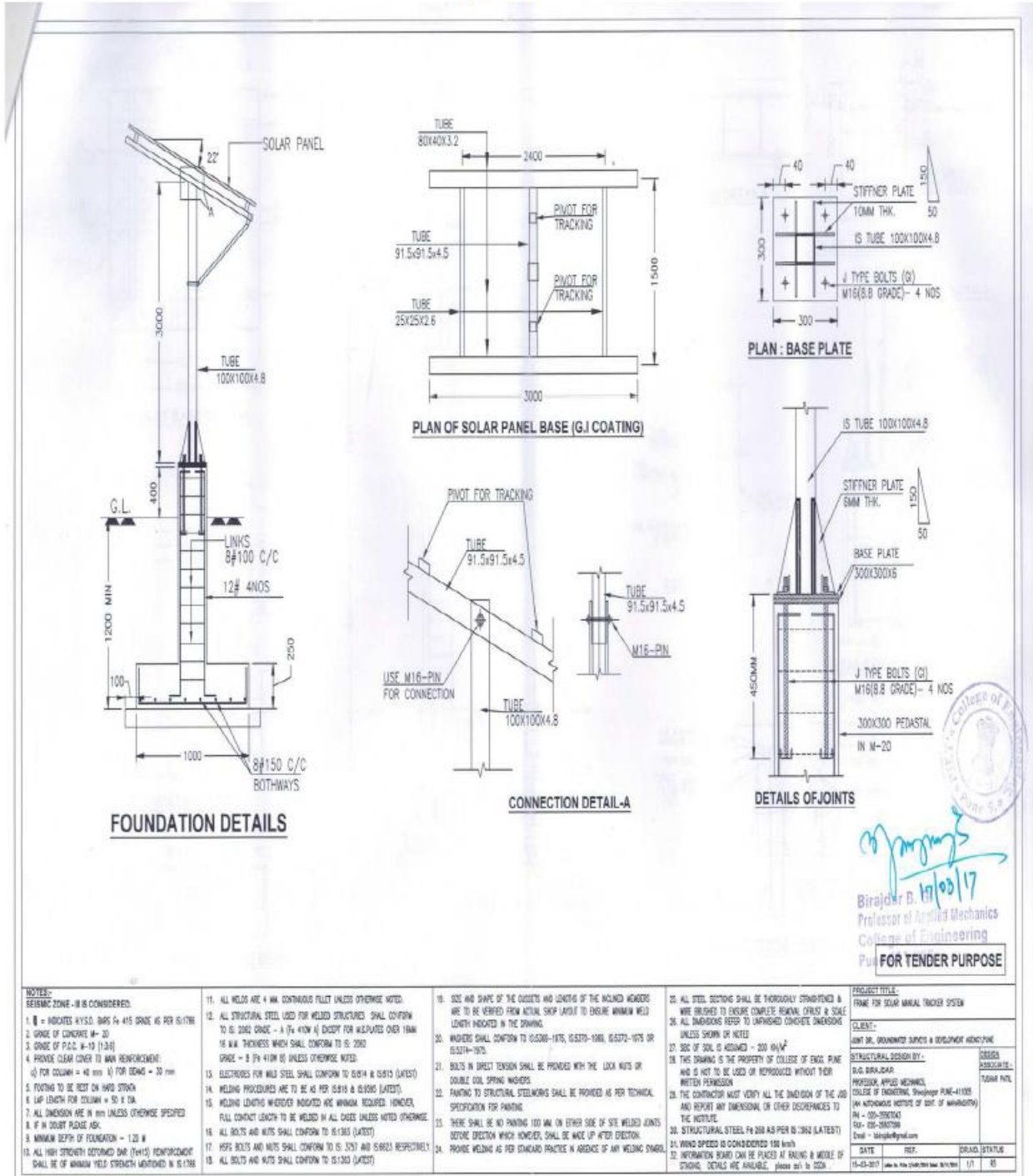

 Brajender B. Singh
 Professor of Applied Mechanics
 College of Engineering
 For TENDER PURPOSE

<p>NOTES: SEISMIC ZONE - III IS CONSIDERED.</p> <ol style="list-style-type: none"> 1. Ø = INDICATES HYSD. BARS Fe 415 GRADE AS PER IS:1786 2. GRADE OF CONCRETE M-20 3. GRADE OF P.C.C. M-10 (1:3:6) 4. PROVIDE CLEAR COVER TO MAIN REINFORCEMENT: (i) FOR COLUMN = 40 mm (ii) FOR BEAMS = 30 mm 5. FOOTING TO BE REST ON HARD STRATA 6. LAP LENGTH FOR COLUMN = 50 Ø DIA 7. ALL DIMENSION ARE IN mm UNLESS OTHERWISE SPECIFIED 8. IF IN DOUBT PLEASE ASK. 9. MINIMUM DEPTH OF FOUNDATION = 1.20 m 10. ALL HIGH STRENGTH OBTAINED BAR (HYSD) REINFORCEMENT SHALL BE OF MINIMUM YIELD STRENGTH MENTIONED IN IS:1786 	<ol style="list-style-type: none"> 11. ALL WELDS ARE 4 MM CONTINUOUS FILLET UNLESS OTHERWISE NOTED. 12. ALL STRUCTURAL STEEL USED FOR WELDED STRUCTURES SHALL CONFORM TO IS 2062 GRADE - A (Fe 415W A) EXCEPT FOR WELDED OVER 15MM 16 MM THICKNESS WHICH SHALL CONFORM TO IS: 2062 GRADE - B (Fe 415W B) UNLESS OTHERWISE NOTED. 13. ELECTRODES FOR MILD STEEL SHALL CONFORM TO IS:14 & IS:15 (LATEST) 14. WELDING PROCEDURES ARE TO BE AS PER IS:818 & IS:819 (LATEST) 15. WELDING LENGTHS WHEREVER INDICATED ARE MINIMUM REQUIRED. HOWEVER, FULL CONTACT LENGTH TO BE WELDED IN ALL CASES UNLESS NOTED OTHERWISE. 16. ALL BOLTS AND NUTS SHALL CONFORM TO IS:1363 (LATEST) 17. HPSR BOLTS AND NUTS SHALL CONFORM TO IS: 1357 AND IS:6623 RESPECTIVELY. 18. ALL BOLTS AND NUTS SHALL CONFORM TO IS:1303 (LATEST) 	<ol style="list-style-type: none"> 19. SIZE AND SHAPE OF THE GUSSETS AND LENGTHS OF THE INCLINED MEMBERS ARE TO BE VERIFIED FROM ACTUAL SLOPE (AS PER) TO ENSURE MINIMUM WELD LENGTH INDICATED IN THE DRAWING. 20. MEMBERS SHALL CONFORM TO IS:2062-1975, IS:2070-1980, IS:2072-1975 OR IS:2074-1975. 21. BOLTS IN DIRECT TENSION SHALL BE PROVIDED WITH THE LOCK NUTS OR DOUBLE COIL SPRING WASHERS. 22. PAINTING TO STRUCTURAL STEELWORKS SHALL BE PROVIDED AS PER TECHNICAL SPECIFICATION FOR PAINTING. 23. THERE SHALL BE NO PAINTING 100 MM ON EITHER SIDE OF SITE WELDED JOINTS BEFORE DIRECTION WHICH HOWEVER, SHALL BE MADE UP AFTER DIRECTION. 24. PROVIDE WELDING AS PER STANDARD PRACTICE IN ABSENCE OF ANY WELDING SYMBOL. 	<ol style="list-style-type: none"> 25. ALL STEEL SECTIONS SHALL BE THOROUGHLY STRENGTHENED & WIRE BRUSHED TO ENSURE COMPLETE REMOVAL OF RUST & SCALE 26. ALL DIMENSIONS REFER TO UNFINISHED CONCRETE DIMENSIONS UNLESS SHOWN OR NOTED 27. SEC OF SOIL IS ASSUMED = 300 kN/m² 28. THIS DRAWING IS THE PROPERTY OF COLLEGE OF ENGG. PUNE AND IS NOT TO BE USED OR REPRODUCED WITHOUT THEIR WRITTEN PERMISSION 29. THE CONTRACTOR MUST VERIFY ALL THE DIMENSION OF THE JOB AND REPORT ANY DIMENSIONAL OR OTHER DISCREPANCIES TO THE INSTITUTE. 30. STRUCTURAL STEEL Fe 360 AS PER IS:2062 (LATEST) 31. WIND SPEED IS CONSIDERED 150 km/h 32. INFORMATION BOARD CAN BE PLACED AT RAILING & MIDDLE OF STRONG. DETAILS ARE AVAILABLE. please call to 022-
<p>PROJECT TITLE: FRAME FOR SOLAR MANUAL TRACKER SYSTEM</p> <p>CLIENT: SRM. DE. GOVERNMENT SUPER & DEVELOPMENT AGENCY/PUNE</p> <p>STRUCTURAL DESIGNER BY: SUG. BHAJENDAR PROFESSOR, APPLIED MECHANICS, COLLEGE OF ENGINEERING, SWAJEEHR PUNE-411005 (AN AUTONOMOUS INSTITUTE OF GOVT. OF MAHARASHTRA) Ph - 020-2567043 Fax - 020-2567099 Email - bhaib@rediffmail.com</p> <p>DESIGN ASSOCIATE: TUSHAR PATIL</p> <p>DATE: 17/03/17 REF.: DRAG STATUS: 1/1 83</p>			

ANNEXURE-B

Survey Format for Solar Energy Based Dual Pump Pipe Water Supply

(To be jointly surveyed by RWS&S, OREDA, Village Representative, Executing firm, details to mention wherever necessary)

1. Name of the habitation
2. Name of Village
3. GP
4. Block
5. Sub division
6. Number of HH in the habitation
7. Bore well / Sanitary well / any other
8. Water table of well, static when surveyed
9. Min water level, if sanitary well, during summer
10. Yield of bore well/ Well 2000 litre per hour
11. Recharging / yield of sanitary well lit per hour
12. Depth of well in mts
13. Length of casing pipe
14. Distance of habitation from source in mts
15. Site for Over head tank(OHT) & module
free from shed / tree
16. Distance from source to OHT in mts
17. Distance of source from the highest point of habitation
18. Sample sketch to draw/ Layout of Site .

Signature

Firm
Representative

Signature

Village
Representative

Signature

OREDA
Asst. Director/
Supervisor.

Signature

RWS&S
Authorised
Officer

ANNEXURE- D

DETAIL OF SYSTEM INSTALLED

S N	Name of the items installed/supply / installations commissioned at site	Unit	Quantity	Remark
1	900 Wp SPV Module of _____Wp each of _____make as per tender specifications along with IV curve details of every individual panel with anti theft fittings with lightning arrester.	No.		
2	1HP(equivalent) Submersible DC, HR / roto-dynamic equivalent pump with MPPT pump controller with suitable indications and controls as per valid test certificate.	No.		
3	All fittings for conversion of hand pump to dual pump including SS cylinder, nipple, water chamber, strainer / filter.	Set		
4	LDPE (ISI) Overhead Tank of capacity 5000 liters. Suitable Hot Dipped Galvanized MS Structure and civil installation as per design	Set		
5	Auto Water Level Controller without Battery	Set		
6	Cable recommended	mtr/no		
7	Lift cock Taps / Common stand post and platform with proper drainage channel arrangements 1 set	Set		
8	GI / CPVC/ UPVC/LDPE Pipe with valves as per relevant standard	mtr/no		
9	Civil Supply / installation of Platform for Pump with proper drainage channel arrangements and 1 soak pit .	Mtr & no.		
10	Firm and fixed ladder up to the solar module for cleaning , barbed wire fencing / guard at the base ground etc	no.		
11	Display board with dos and don'ts			

Seal and
SignatureSarpanch/VWSC
In-ChargeSeal and
SignatureAuthorized
OfficerSeal and
SignatureOREDA
OfficerSeal and
Signature

RWSS

ANNEXURE-E**Scope of Comprehensive maintenance of Solar energy based dual pump piped water supply systems for a period of 5 years. (Contract draft subject to revision)**

All materials, components of the Solar energy based dual pump piped water supply systems during the period of maintenance shall be the property Village Committee where the system is installed.

Regular maintenance of the all Systems for a period of 5 years of warranty against manufacturing defects after commissioning along with supply of consumable items as and when necessary and submission of daily performance of solar submersible pump systems shall come, under the comprehensive maintenance contract.

The break down maintenance of the entire system including supply of necessary spare parts, if any are already under the coverage of warranty clause of the General Terms & Condition and special terms & condition for a period of 5 years from date of commissioning of solar submersible pump systems. The operation and maintenance schedule of the SPV solar submersible pump systems during the 5 years contract period shall be as detailed below.

1. 5 years comprehensive maintenance period shall begin on the date actual commissioning for the solar submersible pump systems. The requisite numbers of qualified and trained personnel are required to be deputed / available in the state.
2. The security of the solar submersible pump systems will rest with the village committee till such time comprehensive maintenance of the solar submersible pump systems.
3. The deputed personnel shall be qualified and well trained so that they can handle any type of operation hazard quickly and timely.
4. The deputed personnel shall have to keep the record on quarterly basis for the solar submersible pump systems as per format to be supplied after commissioning of the solar submersible pump systems.
5. The deputed personnel shall be in a position to check and test all the equipment regularly, so that preventive actions, if any, could be taken well in advance to save any equipment from damage.
6. The Village Committee shall keep clean the solar submersible pump systems in all time.
7. Normal and preventive maintenance of all systems all electrical connection, changing of tilt angle of module mounting structure shall be the responsibility of the supplying agency.

8. During the maintenance period of 5 years of the solar all systems, if there is any defect of any component of all systems the supplier shall be responsible for immediate replacement / rectification. The damaged component may be repaired, if it is understood after examination that after repairing performance of the component shall not be degraded, otherwise the defective component shall have to be replaced by new one without any extra cost.
9. List of spare parts & measuring instruments are to be supplied along with the systems may be specified in the bid.

10. Comprehensive Maintenance Instructions:

- 10.1 The executants shall furnish prior to completion of the supply / installations copies of maintenance instruction in Odiya / English for approval and supply sets of the approve manuals of instructions at the time of inspection and taking over of the equipment. These manuals shall properly bound in book form and contain all information, description of equipment, diagram etc. necessary to enable the customer to operate and maintain the whole scheme.
- 10.2 Proper maintenance of the systems shall be carried out by the executants during the maintenance period of 60 months with 6 monthly / annual review check up of systems and equipment in detail with purchaser.
- 10.3 Properly qualified and trained personnel well versed in maintenance of SPV systems and knowledge of computers with approval from purchaser shall be deployed at site for maintenance.
- 10.4 Proper repainting, re-coating of exposed surfaces to prevent rusting & replacement of worn out parts shall be carried out along with the maintenance.
 - Systems personnel shall be deputed on such basis so that a qualified / trained person with a minimum Technical qualification should be available at site always during the maintenance period.
 - Supplier shall depute on engineer of their company for the maintenance of the systems who shall be fully responsible for the complete maintenance and optimum operation of the systems. The name and contact nos. of this engineer shall be notified to the purchaser for the purpose of contact, responsibility and correspondence with regard to all trouble shooting.
 - Replacement & repair of damaged parts shall be carried out immediately during the maintenance period so as to ensure at least 95% uptime.
 - Systems operation reports in a format prescribed by the purchaser shall be furnished by the supplier on a weekly and monthly basis.

- Systems shall be operated as per the standard practices to ensure proper safety measures.
- The supplier shall ensure replacement of worn out parts and component during the comprehensive maintenance period for which purpose the supplier shall carry and maintain minimum inventory of spares at the systems and its supply / installations.
- In case of delay in repair & maintenance and non-observance of schedule, the purchaser shall have the right to impose any penalties including forfeiture of performance security.
- In case of any fault, the fault must be removed within 2 days of receipt of the complaint, failing which a penalty of Rs.1,000/- per day shall be charged. In case of delay of more than 7 days OREDA may on its take up repair by any suitable method and the cost of the repair along with the penalty amount will be charged from the supplier to be paid or deducted from the performance security deposit by invoking the BG in part to the extent of the repair cost. However, under Force Majure circumstances penalty can be waived off.

10.5 Routine, preventive, breakdown& Capital Maintenance :

- Routine and Preventive maintenance shall include such checks and maintenance activities quarterly / half yearly and yearly basis which are required to be carried out on all the components of the solar submersible pump systems to minimize breakdown and to ensure smooth and trouble free running of the all systems. The supplier shall be responsible to carryout routine and preventive maintenance and replacement of each and every component/ equipment of the solar submersible pump systems and he shall provide all labour, materials, consumables etc. for routine and preventive maintenance of his own cost.
- Breakdown maintenance shall mean the maintenance activity including repairs and replacement of any component or equipment of the all systems which is not covered by routine and preventive maintenance and which is required to be carried out as a result of sudden failure / breakdown of that particular component or equipment while the systems is running. The supplier shall be responsible to carry out breakdown maintenance of each and every component of the solar submersible pump systems and he shall provide the required manpower, materials, consumables, components or equipment etc. for breakdown maintenance at his own cost irrespective of the reasons of the breakdown/ failure.
- Capital maintenance shall mean the major overhaul of any component or equipment of the solar submersible pump systems which is not covered by routine, preventive and breakdown maintenance which may become

necessary on account of excessive wear & tear, aging which needs repair / replacement. The capital maintenance of solar submersible pump systems and all civil structures shall normally be planned to be carried out on an annual basis. For this purpose a joint inspection by the supplier and purchaser shall be carried out of all the major components of the solar submersible pump systems, about two months in advance of the annual maintenance period. In order to ascertain as to which components of the solar submersible pump systems require capital maintenance. In this regard the decision of the purchaser will be final and binding. However, if the condition of any systems and component warrants its capital maintenance at any other time, a joint inspection of the purchaser and supplier shall be carried out immediately on occurrence of such situation and capital maintenance shall be carried out. If required, in consultation with concerned authorities. The decision of the purchaser shall be final and binding.

Signature of the bidder

ANNEXURE-F

Model Bank Guarantee Format for Performance Security

To

The Chief Executive,
 OREDA, Bhubaneswar

WHEREAS----- (name and address of the supplier) (hereinafter called "the supplier") has undertaken. in pursuance of contract no----- dated----- to supply ----- (description of goods and services) (herein after called "the contract")'

AND WHEREAS it has been -stipulated by you in the said contract that the supplier shall furnish you with a bank guarantee by a scheduled commercial bank recognized by you for the sum specified therein, as security for compliance with its obligations in accordance with the contract;

AND WHEREAS we have agreed to give the supplier such a bank guarantee;

NOW THEREFORE we hereby affirm that we, are guarantors and responsible to you on behalf of the supplier. up to a total as detailed below . (Amount of the guarantee in words and figures). and we undertake to pay you.

1. 1 year@ 2%, Valid from ----- to ----- Rs. -----
2. 2 years@2%, Valid from -----to ----- Rs-----
3. 3 Years@2%, Valid from -----to ----- Rs-----
4. 4 years@2%, Valid from ----- to ----- Rs. -----
5. 5 years@2%, Valid from -----to -----Rs.-----

Upon your first written demand declaring the supplier to be in default under the contract and without cavil or argument, any sum or sums within the limits of (amount of guarantee) as aforesaid. without your needing to prove or to show grounds or reasons for your demand or the sum specified therein.

We hereby waive the necessity of your- demanding the said debt from the supplier before presenting us with the demand.

We further agree that no change or addition to or other 'modification of the terms of the contract to be performed there under or of any of the contract documents --which may be made between you and the supplier shall in any way release us from any liability under this guarantee and we hereby waive notice of any such change. Addition or modification.

This guarantee shall be valid as indicated above .

Our branch at * (Name & Address of the ____ * branch) is liable to pay the guaranteed amount depending on the filing of claim and any part thereof under this Bank Guarantee only and only if you serve upon us at our----- * branch a written claim or demand and received by us at our ____ * branch on or before Dt.-----otherwise bank shall be discharged of all liabilities under this guarantee thereafter.

(Signature of the authorized officer of the Bank)

Name and designation of the officer

Seal. name & address of the Bank and address of the Branch

FORMAT FOR BANK GUARANTEE FOR EMD

On stamp paper of requisite amount

ANNEXURE-G

B.G. No:.....

To

The Chief Executive

OREDA, Bhubaneswar

Whereas 'OREDA' has invited tender for the work of Design, supply, installation, commissioning and maintenance of SPV Systems vide Tender Call Notice No.-----/OREDA AND WHEREAS M/S. (Name and address of the firm), who having submitted their tender hereinafter referred to as the 'Tenderer' and have agreed to deposit to the 'OREDA' an amount of Rs..... (Rupees) as per the terms and conditions of the Tender Document AND WHEREAS the 'OREDA' also willing to accept a Bank guarantee in lieu of payment by demand draft of any amount equivalent to the amount of earnest money required to be deposited by the Tenderer to the 'OREDA' i.e. an amount equal to Rs..... which as guarantee will be kept valid up to -----.

In consideration of the 'OREDA' having agreed to consider the Bid proposals submitted by the tenderer without depositing the amount of earnest money and against this Bank guarantee, we(name and address of the bank) hereby undertake and guarantee to make payment to the 'OREDA' the amount of Bid earnest money deposit at any time (time being the essence of the contract) when the 'OREDA' asks for the same as per the terms and conditions of the tender Document.

The bank further undertakes not to revoke this guarantee during its currency except with the previous consent of the 'OREDA' in writing and the guarantee shall be continuous and irrevocable guarantee up to a sum of Rs..... (Rupees.....)only provided always that any indulgence or relation on the part of the 'OREDA' to the said tenderer with or without the consent of the bank shall not prejudice or restrict remedies against the bank nor shall the same in any event be a ground of defence by the Bank against the 'OREDA'.

In case the 'OREDA' Force puts forth a demand in writing on the Bank for the payment of amount full or in part against this bank guarantee, the bank will consider that such demand by itself is a conclusive evidence and proof that the tenderer has failed in complying with the terms and conditions stipulated by the 'OREDA' in its bids and payment will be made to the 'OREDA' without raising any disputes regarding the reasons for such failure on the part of the tenderer.

The bank shall not be discharged for release from this guarantee by any arrangement between the tenderer and the 'OREDA' with or without the consent of the bank or any alterations in the obligations of the parties or by an indulgence, forbearance shown by the 'OREDA' to the tenderer.

This guarantee shall be in addition to and without prejudice to any other securities or remedies which the 'OREDA' may have or hereafter possess against the tenderer and the 'OREDA' shall be under no obligations to marshal in favour of the bank any such securities or fund or asset that the 'OREDA' at its

absolute discretion may vary, exchange, renew, modify or refuse to complete or enforce or assign any security or instrument.

The Bank agrees that the amount hereby guaranteed shall be due and payable to the 'OREDA' on 'OREDA' serving a notice requiring the payment of the amount and such notice shall be served on the bank either by actual delivery thereof to the Bank or by dispatching thereof to the bank by Registered post at the address of the said Bank. Any notice sent to the Bank at its address by Registered Post shall be deemed to have been duly served on the Bank notwithstanding that the notice may not in fact have been delivered to the Bank.

In order to give full effect to the provisions of this guarantee the bank thereby waives all rights inconsistent with the above provisions and which the bank might otherwise as a guarantor be entitled to claim and enforce.

We,.....(name and address of the bank), lastly undertake not to revoke this guarantee during its currency except with the previous consent of the 'OREDA' in writing.

“Notwithstanding anything contained herein”,

- (i) Our liability under this guarantee shall not exceed Rs..... (Rupees only).
- (ii) This Bank Guarantee shall be valid up to -----
- (iii) We are liable to pay the guaranteed amount or any part thereof under this Bank Guarantee only and only if we receive from you a written claim or demand on or before -----
----- (date of expiry of Guarantee)”.

Dated:-.... day of 2018

ANNEXURE- H

PRICE BID –Model-I
ONLINE

As per MNRE/ JNNSM/ Other national / international standards on components / systems with terms and condition on warranty / replacements, performances

Sl no	Particulars	Price in INR
1	<p>Supply of Solar Photovoltaic Water Pumping System consisting of 1 HP (equivalent), submersible DC (HR / equivalent pump) set and Photovoltaic solar panel set of 675 Wp, lightning arrester, water level auto control & electronics etc. complete as per technical specification.</p> <p>Supply of 25 LDPE independent riser pipe of maximum 60m along with stainless cylinder, nipples, special water chamber, strainer / filter to the pump, necessary fittings to the Solar Photovoltaic water submersible pump set, etc. complete to convert a hand pump to dual pump as per GSDA specification / drawing.(In case of sanitary well float arrangement to provide complete in all respect)</p> <p>Supply of Hot dip galvanized MS Steel staging as per technical specification for composite structure for water storage tank at 3m and solar PV panel at top height with ladder up to the module for servicing or for model-I</p> <p>Supply of materials for rising main up to 50m, distribution system with 63mm piping, one galvanized stand posts with 4 taps and 5000 L LDPE (ISI) water storage tank at the locations point on the basis of the joint survey of OREDA / RWS&S etc within 15 m diameter from the hand pump, closest to the habitation as per technical specification.</p> <p>Supply of barbed wire fencing for the ladder/ solar PV panel / staging structure at the ground base, display plate of the supplier/executants, IEC materials to display.</p>	

	Supply of Construction material for foundation for hot dip galvanized MS Steel Staging for LDPE(ISI) water storage tank, solar panel and stand post platforms etc conforming to GOI / GSDA, Maharashtra plan and drawing.	
	Total	
2	Taxes and duties	
3	Sub Total (1 +2)	
4	Rates for Installation and commissioning of the systems	
5	Taxes and duties	
6	Sub Total	
7	Grand Total (3+6)	

(In words-----)

Signature of the bidder with Seal

ANNEXURE- I

PRICE BID FOR MODEL-II
ONLINE

As per MNRE/ JNNSM/ Other national / international standards on components / systems with terms and condition on warranty / replacements, performances

Sl no	Particulars	Price in INR
1	<p>Supply of Solar Photovoltaic Water Pumping System consisting of 1 HP (equivalent), submersible DC (HR / equivalent pump) set and Photovoltaic solar panel set of 675 Wp, lightning arrester, water level auto control & electronics etc. complete as per technical specification.</p> <p>Supply of 25 LDPE independent riser pipe of maximum 60m along with stainless cylinder, nipples, special water chamber, strainer / filter to the pump, necessary fittings to the Solar Photovoltaic water submersible pump set, etc. complete to convert a hand pump to dual pump as per GSDA specification / drawing.(In case of sanitary well float arrangement to provide complete in all respect)</p> <p>Supply of Hot dip galvanized MS Steel staging as per technical specification for composite structure for water storage tank at 3m for model-II.</p> <p>Monopole MS galvanized module structure as per technical specification.</p> <p>Supply of materials for rising main up to 50m, distribution system with 63mm piping, one galvanized stand posts with 4 taps and 5000 L LDPE (ISI) water storage tank at the locations point on the basis of the joint survey of OREDA / RWS&S etc within 15 m diameter from the hand pump, closest to the habitation as per technical specification.</p> <p>Supply of barbed wire fencing for the ladder/ solar PV panel / staging structure at the ground base, display plate of the supplier/executants, IEC materials to display.</p>	

	Supply of Construction material for foundation for hot dip galvanized MS Steel Staging for LDPE(ISI) water storage tank, solar panel and stand post platforms etc conforming to GOI / GSDA, Maharashtra plan and drawing.	
	Total	
2	Taxes and duties	
3	Sub Total (1 +2)	
4	Rates for Installation and commissioning of the systems	
5	Taxes and duties	
6	Sub Total	
7	Grand Total (3+6)	

(In words-----)

Signature of the bidder with Seal

ANNEXURE- J

PRICE BID
ONLINE

For extra distribution, piping, hand pump supply and platform construction.

1 . Distribution:

Sr.No	Particulars	Rates in INR
1	Distribution and connections at the door steps from main distribution line with LDPE/ CPVC pipe as per IS of 63 mm size shall be used to connect solar dual pump to over head tank and over head tank to stand post below ground level connection at a depth of minimum 60cm of required length with provision of 1/8 ferrule connection should be provided by the supplier. Only GI pipe of 50/32 mm size shall be used for over ground connection such as inlet, outlet and over flow connection of OHT connecting to LDPE pipe from submersible pump and to distribution line connected to Four mouth hot dip galvanised Common stand post with stainless steel self closing (304 grades)taps at a height 800mm. After testing of the pipe distributions and stand posts the trenches to be filled up with excavated earth up to a depth of 30 cm watering and riming and making good to the damages of the road as per pre road condition (WBM/CC/Bituminous).	
	a) With LDPE pipe per mtr, with taxes	
	b) With GI pipe per mtr with taxes	
2	Common stand post of four taps.	

2. Hand pump:

Sr.No	Particulars	Price in INR
1	Demolishing of existing Hand Pump platform with taxes.	
2	Supply of India Mark II Hand Pump Set with 70 mm OD stainless steel cylinder along with 12 nos of GI Pipes and connecting rods 3 meters each with taxes.	
3	Construction of platform for Hand Pump (inclusive of taxes and duties) with taxes.	

Signature of bidder with seal and date