

ODISHA RENEWABLE ENERGY DEVELOPMENT
AGENCY

S/59, MANCHESWAR INDUSTRIAL ESTATE
BHUBANESWAR-751010, ODISHA

Tender
For
Standard Rate Contract
For a period of 1 year

Design, Supply, Installation, Commissioning and Maintenance of Flat
plate solar water heating system
in the state of Odisha

Tender Call Notice- 2241 /OREDA
Dated-3.10.2015

Tel-06742588260, 2586398, 2585898,2580554,2581552, ,

Fax-2586368, Web site: www.oredaodisha.com.

E-mail : ceoreda@oredaodisha.com

This bid document along with Annexures as per Index is issued to

M/s _____

Kindly Note:

1. This document is not transferable
2. Though adequate care has been taken for preparation of this document, the bidder shall satisfy himself that the document is complete in all respects. Intimation of any discrepancy shall be given to this office immediately. If no intimation is received from any bidder within ten days from the date of issue of the bid document, it shall be considered that bid document is complete in all respects and has been received by the bidder.
3. The Odisha Renewable Energy Development Agency (OREDA) reserves the right to modify, amend or supplement this bid document.
4. While the bid has been prepared in good faith, neither OREDA nor their employees or advisors make any representation, warranty, express or implied or accept any responsibility or liability, whatsoever, in respect of any statements or omissions herein, or the accuracy, completeness or reliability of information, and shall incur no liability under any law, statute, rules or regulations as to the accuracy, reliability and completeness of this bid document, even if any loss or damage is caused by any act or omission on their part.

OREDA

Tel:(0674)2580554

Fax: (0674) 2586368

Email:ceoreda@oredaorissa.com

Place: Bhubaneswar

Disclaimer

Kindly Note:

1. This document is not transferable
2. Though adequate care has been taken for preparation of this document, the bidder shall satisfy himself that the document is complete in all respects. Intimation of any discrepancy shall be given to this office immediately. If no intimation is received from any bidder on the pre bid meeting or within ten days from the date of issue of the bid document, it shall be considered that bid document is complete in all respects and has been received by the bidder.
3. The Odisha Renewable Energy Development Agency (OREDA) reserves the right to modify, amend or supplement this bid document keeping in view the necessity in implementation of the scheme.
4. While the bid has been prepared in good faith, neither OREDA nor their employees or advisors make any representation, warranty, express or implied or accept any responsibility or liability, whatsoever, in respect of any statements or omissions herein, or the accuracy, completeness or reliability of information, and shall incur no liability under any law, statute, rules or regulations as to the accuracy, reliability and completeness of this bid document, even if any loss or damage is caused by any act or omission on their part.

Index

Background.....	05
Important Dates.....	.06
Check List of Documents.....	7-8
List of Abbreviations.....	9
1. Eligibility Criteria.....	10
2. Scope of Work.....	10-11
3. Functional Requirements for installation of solar water heating system	11
4. Instruction to Bidder.....	12
5. Procedure for Opening the Bid.....	14
6. Acceptance/ Rejection of the Bid Document.....	15
7. Commercial Terms & Conditions.....	15
7.1. Rate.....	15
7.2. Sales Tax & Duties etc.....	15
7.3. Earnest Money Deposit.....	15
7.4. Security Deposit.....	16
7.5. Performance Guarantee.....	16
7.6. Allocation of Work.....	16
7.7. Programme Execution Schedule.....	17
7.8. Quantity.....	17
7.9. Validity of Offer.....	17
7.10. STCC/VAT.....	17
7.11. Warranty.....	17
7.12. Penalty & Termination of Contract.....	18
7.13. Force Majeure.....	18
7.14. Inspection.....	18
7.15. Payment.....	18
7.16. Execution.....	19
7.17. Comprehensive Maintenance Contract.....	19
7.18. Limitations of Liability.....	19
6.18. Dispute.....	19
Technical Specifications.....	.20

Background:

Orissa Renewable Energy Development Agency (OREDA) is the state level nodal Agency under Science & Technology, Dept, Govt of Orissa to implement renewable energy programme/scheme in the state.

OREDA have decided to set up Solar water heating system with different capacities starting from 100 LPD to 3000 LPD at 60 ° C in the individual households / institutions (Govt/ Private) in state of Odisha for supply of hot water with the financial support of MNRE, GOI and User .

In the above backdrop, this tender for Standard Rate Contract for Design, Supply, Installation, Commissioning and Maintenance solar water heating system and Installation of (ISI mark) HDPE tank with support structure of various capacities is being floated with a view to empanel competent vendors for the undertaking the above works at competitive prices.

Important Dates

1	Uploading of bid documents on web site	6.10.2015
2	Pre bid meeting held	17.10.2015 at 11.00 AM
3	Sale of revised final Bid documents after pre bid meeting	On all working days from 6.10.2015 to 4.11.2015.
3	Last date of receipt of bids	5.11.2015 till 3PM
4	Date of opening of technical bids	5.11.2015 at 3.30PM
5	Date of opening of price bid of techno commercially qualified bidders	To be intimated

Check list of documents to be submitted along with the bid

Sl no	Particulars	Complied	Page-no / Flag
1	Bank draft for Rs.10500/- or original money receipt issued by OREDA as proof of purchase of tender paper or exempt as admissible with proof	Bank No Dt	Envelop
2	Bank draft for Rs 1.00 lakhs towards Earnest Money Deposit or exempt as admissible with proof.	Bank No Dt	Envelop
3	Forwarding letter duly signed and stamped by the bidder		
4	Undertaking duly signed and stamped by the bidder.		
5	Document stating the status of the bidder as manufacturer /systems integrator		
6	Copy of the PAN card of the bidder's firm		
7	Copy of the TIN card of the bidder's firm		
8	Copies of Tax returns, VAT/ STCC/ e-filing		
9	Document stating annual turnover in solar business duly signed and stamped by a registered chartered accountant on the letter head of the chartered accountant		
	Annual audited balance sheets for 2012-13		
	Annual audited balance sheet for 2013-14		
	Annual audited balance sheet for 2014-15		
10	Proof of installation of 2000 LPD (40 sq meter collector area) or more Solar water heating system in Govt / PSU/ individual households in the country . Copies of completion certificates given by the users to be enclosed		
11	Proof of Production capacity of solar water heating system.		
12	Proof of local registration with DIC/ NSIC/		

	MSME/ EPM for undertaking solar business		
13	Proof of establishment of Quality assurance systems and organisation		
14	Valid Test reports as per MNRE guideline under JNNSM		
15	Willingness to open an office as well service centre in the state of Odisha		
16	Undertaking for Indigenous of the supplied items		
17	All accounting statements with auditor's note duly signed by a Chartered Accountant		
18	Undertaking to unconditionally accept all terms and conditions of the bid document with copy of Board Resolution		
19	Power of attorney to sign the agreement on behalf of bidders & partnership deed articles, if any.		
20	Filled in bid document duly signed and stamped at the bottom of each page except the price bid format.		
21	Organizational profile containing the original documents defining the constitution or legal status, place of registration.		
22	Signed Technical bid in sealed envelop		
23	Price bid in separate single sealed envelope and no other content		

List of Abbreviations

Admn	Administration
LPD-	liter per day
Asst	Assistant
BG	Bank Guarantee
BIS	Bureau of Indian Standards
CMC	Comprehensive Maintenance Contract
DD	Demand Draft
EMD	Earnest Money Deposit
GOI	Government of India
GPS	Global Positioning System
IS	Indian Standards
JCC	Joint Commissioning Certificate
JnNSM	Jawaharlal Nehru National Solar Mission
MNRE	Ministry of New and Renewable Energy
OREDA	Orissa Renewable Energy Development Agency.
SNA	State Nodal Agency
SWG	Standard Wire Gauge
Sqm	Square Meter
STCC	Sales Tax Clearance Certificate
TIN	Temporary Identification Number
VAT	Value Added Tax

1. Eligibility Criteria

In order to be eligible to participate in this tender for rate contract a bidder must have the following eligibility criteria

1. The firm should be solar thermal device manufacturer/authorized dealer /system integrator .
2. Must have BIS certificate on solar water heating system as per MNRE guideline.
3. The firm must have a minimum total turnover of Rs 1 crore over last three years.
4. The firm must have installed at least 2000 LPD (40 sq meter collector area) Solar Water Heating System.
5. Notwithstanding to any of the clauses local firm registered with state DIC/MSME/NSIC for last 5 years and carrying out solar business in Odisha will be eligible to participate in the tender. All such firm will be governed by relevant OMSME policy 2009 therein.

1.1 General

- a. All bidders must have valid STCC/ VAT clearance certificate issued by appropriate authority as on the date of submission of the bid. copy of valid STCC/ VAT clearance certificate must be submitted along with the technical bid.
- b. The products must conform to technical requirements/ standards for solar water heating system to be deployed under the National solar Mission and the firm must have established necessary quality assurance systems and organization in line with the same.
- c. The bidder must be having or willing to open an authorized office in the state of Odisha
- d. The bidders must be having or willing to open properly equipped service centres in the vicinity of their area of operation in the state of Odisha.

2. Scope of the work

Orissa Renewable Energy Development Agency (OREDA) proposes to set up Solar Water Heating System at 60 ° C.

Scope of work includes: -

1. Design, supply, lifting, installation, commissioning and maintenance of Solar Water Heating System in the individual households / institution of different capacities from 100 LPD to 3000 LPD with required specification as per MNRE, GOI guideline along with other additional works required at site.
2. The supplier shall after completion and commissioning of the work submit details of the same in the format.
3. Comprehensive Maintenance Contract (CMC) of the solar water heating system for five years. The date of commencement of the CMC shall be reckoned from the date of commissioning of the solar water heating system.
4. User may not have overhead tank at appropriate height for smooth supply of cold water to the solar water heater system In such cases supply, installation, commissioning of ISI mark HDPE water tank with MS support Structure of different capacities from 200 liters to 1000 liters to be provided. For which specific work order will be issued in favour of successful firm for installation of such tank. The supplier is to install the HDPE tank with structure with proper civil foundation & grouting.(1:3:4) .The supplier will also to connect cold water input line to HDPE tank with required fittings along with float valve and one gate valve for commissioning the project.
5. The materials to be supplied to the respective sites should be as per the specification with at least five years warrantee period on the system commissioned by the firm.

6. The firm shall after completion and commissioning of the work submit details of the same in the format.
7. The bidders has to identify the prospective customers/beneficiary i.e. marketing has to be done by successful bidder itself and OREDA will also provide the list of beneficiary if available. OREDA will also provide necessary support in identification of beneficiary through paper advertisement, exhibition under IEC activities. The successful bidders has to execute the supply, installation and commissioning of the SWHS after getting due approval from OREDA. Bidder will reimburse /beneficiary will be entitled to the eligible subsidy amount subject to availability of funds / sanction of MNRE as per the guideline. In such case the bidder/beneficiary should submit required documents and proof of installation of SWHS. OREDA shall keep 5 % of the system cost as processing fees.
Besides, OREDA may also place work order with the successful bidder against the deposit work received from user and payment will be made accordingly.
8. Sensitization and awareness generation about solar thermal systems.

2.1 General

- a. Execution of Comprehensive Maintenance Contract (CMC) of the complete system for five years warranty period. The date of commencement of CMC shall be reckoned from the date of commissioning of the system.
- b. Opening of service centre/keeping servicing personnel and making available all essential spares in the vicinity of the SWHS so that the system will give the desired performance with least interruption.
- c. Training at least two designated persons from the concerned user organization as well as all designated technical persons of OREDA in day to day maintenance and upkeep of the system.
- d. Submission of quarterly performance reports and other information as per the MIS prescribed by OREDA

3. Functional requirements for installation of solar Water heating system :

3.1 Installation:

- a) While installing solar water heating system on rooftops the physical condition of the rooftop should be taken in to consideration.
- b) There should not be any damage what so ever to the roof top due to setting up of the solar collector so that on a later day there is leakage of rain water, etc. from the roof top.
- c) In case small damages are inevitable for erecting the footings for the collector and hot water storage tank mounting structure etc. the roof top may be given a suitable grading plaster with suitable leak proof compound so as to render the roof entirely leak proof. .
- d) The solar water heating system must be installed on the roof top in such a way that there is sufficient space on the roof top for maintenance etc.
- e) If the roof top does not have any access such as stairs or Ladder, a proper and safe ladder must be provided to ensure easy access to the roof top mainly for the purpose of maintenance and inspection.

- f) The roof top should look clean and tidy after installation of the system.
- g) Neatness, tidiness and aesthetics must be observed while installing the systems.

3.2 System Requirements:

- a. The system should give rated output at least 300 days in a year.
- b. There should not be any leakage in the storage tank and hot water piping.
- c. The system should be as per the MNRE standard

4. Instruction to Bidders

- a. Bids must be submitted in English language only.
- b. Incomplete, telegraphic or conditional bids shall not be accepted.
- c. Prices quoted must be firm and fixed. No price variation / escalation shall be allowed during the validity period of the rate contract..
- d. The bidders must sign and stamp at the bottom of each page of the bid documents at the time of submission in token of unconditional acceptance of the departmental terms and conditions, technical specifications etc.
- e. Last IT returns Statement /Valid TIN / VAT/ Sales tax clearance certificate duly attested must be submitted along with the bid.
- f. Deviations in terms and conditions, Specification of material, Inspection clause etc. will not be accepted under normal conditions. However under exceptional situation the same may be considered at the discretion of OREDA.
- g. Earnest money as specified in bid may be deposited in shape of Demand Draft drawn in favour of the Chief Executive, OREDA payable at Bhubaneswar from any Nationalized Bank. **Bids without E.M.D will not be accepted.**
- h. Bids received late due to postal delay or otherwise **will not be considered.**
- i. The bidders are required to furnish their offers in the price bid both in words & figures. In case of corrections ,if any, the original text/numerical must be clearly crossed out and re-written legibly above, below or on the side of the crossed out characters as per availability of space and the authorized person must put his dated initial under such corrections. In case of any conflict between figures and words, the later shall prevail.
- j. Canvassing in any manner shall not be entertained and will be viewed seriously leading to rejection of the bid.
- k. Certificate to the effect that the systems to be supplied are indigenous & not fully imported must be furnished.
- l. All essential supplementing documents should be signed and stamped and in case of need for verification, originals should be produced

- m. Copy of Test Reports /BIS certificate on Solar Collector confirming to MNRE specifications spelt out in the Administrative Approval of Jawaharlal Nehru National Solar Mission would be a major criteria for evaluation of bids.
- n. The bidders must be having / willing to open a local office at Bhubaneswar before commencement of work for close coordination with OREDA and also cluster level service centres at suitable places as will be indicated by OREDA during installation of the systems. **The firm should open an Office in Odisha and register under Odisha VAT Act before commencement of works.**
- o. The bidders must submit information such as GPS locations of the site, photographs of the systems (**collector, hot water storage tank and cold water tank separately**) along with the installation & commissioning reports.
- p. Power of attorney to sign the agreement on behalf of bidders & partnership deed articles, if any, should be enclosed along with original bid documents.
- q. Notice inviting tender, bid documents, prescribed Technical bid, price bid, terms & conditions will form the part of the tender.
- r. All pages of the bid documents must be signed & sealed by the authorized person on behalf of the bidders.
- s. Bids will be accepted & will be opened as per information mentioned in the notice-inviting tender. No receipt against submission of bid shall be issued by OREDA.
- t. The last date sealed tenders may only dropped in the specified tender box kept in the **Division –I**, OREDA during office hours on working days. Bids received after due date & time will not be considered. The bids of such firms shall only be considered who have purchased the bid documents from the Agency by depositing the prescribed fee of the bid document (Non refundable) / downloaded from the website and submitted along with cost of the tender paper. If due to any reason the due date is declared as a holiday the bid will be opened on next working day at the same time.
- u. The technical bid shall be **opened on 5.11.2015 at 3.30 P.M** in the OREDA office, Bhubaneswar in presence of such bidders or their authorized representatives, who may like to be present at the time of opening.
- v. **Submission of bids**

The first envelop should be superscribed as “Technical Bid” at the top the envelop and name and address of the bidder should be given at the left hand side bottom of the envelope. The first envelop should be addressed to CE, OREDA shall contain the following:

(i) DD of Rs. 10,500/- forwarding cost of the tender if the document is downloaded.

(ii) Copy of the money receipt issued by OREDA in case of the document is purchased directly from OREDA.

(iii) Demand draft for Rs.1.00 lakhs towards EMD

(iv) Filled in Technical Bid Format

(v) All other documents excepting the Price Bid

The second envelop should be superscribed as “**Price Bid**”----- at the top the envelop and name and address of the bidder should be given at the left hand side bottom of the envelope. The second envelop should be addressed to CE, OREDA shall contain the **Price Bid** only in the prescribed format.

The third Envelop should be superscribed as “Submission of Bid for Design, Supply, Installation, Commissioning and Maintenance for a period of 5 years of Flat plate Solar Water Heating System in the state of Odisha” at the top the envelop and name and address of the bidder should be given at the left hand side bottom of the envelope. The third envelop should be addressed to CE, OREDA shall contain the First and second envelops only

Note: All papers that comprise the bid document of the concerned bidder must be numbered at the top right hand corner of each page, properly stitched and hard bound. At the beginning an index of each page should also be provided.

5. Procedure for opening the bids

The procedure of opening of the bid shall be as under

- a. First envelope in the “TECHNICAL BID ” shall be opened at the time & date mentioned in the notice in the tender by OREDA in the presence of bidders, or their authorised representative.
- b. Second envelope “PRICE BID” shall be opened after evaluation of technical suitability of the offers. The date for opening of second envelope (Price bid) shall be communicated subsequently. Second envelope of only those bidders shall be opened who qualify in the technical bid evaluation. If necessary, the firms may be called for Technical Presentation of their products as per the time intimated by OREDA. The successful bidder will be decided by the purchase committee /selection committee based on the price quoted in Annexure-B-I and other credential of the firm. The successful bidder should agree to the price finalised by the committee on the plumbing item of the annexure-B-II to complete the project. For installation of ISI mark HDPE tank with support structure price is to be quoted in annexure- C - (i), (ii) ,(iii) &,(iv) .The successful bidder will be decided by the purchase committee /selection committee based on the price quoted for supply and installation of HDPE tank with support structure.
- c. In case of supply of any defective material or substandard material, the materials will be rejected & it will be the responsibility of the supplier for taking back & replacing the rejected materials at their own cost. In case of non-lifting of such rejected materials within a reasonable time offered by OREDA it will have the right to suitably dispose of the same and forfeit the amount.
- d. The supplied materials should strictly comply with the specifications as mentioned in the bid; otherwise the material would be liable for rejection.
- e. Any clarification on the technical specification and commercial terms and conditions may be raised during the pre-bid meeting for discussion and decision.

- f. Deviation of any commercial terms and condition and technical specification shall not be entertained under no circumstances.
- g. OREDA will not be responsible for any incidental or consequential losses of the bidder while execution and till expiry of the period of CMC.
- h. All the bidders shall essentially indicate the break-up of prices as shown in Price bid.
- i. During the warranty period, MNRE/ State Agencies/ Users reserve the right to cross check the performance of the systems with the minimum performance levels specified in the MNRE specifications.

6. Acceptance/ Rejection of the bid documents

Chief Executive, OREDA reserves the right to

- i) Reject or accept any or all bids without assigning any reason thereof.
- ii) To split the quantities against the bid on more than one firm for the same items/ work.

No reason will be assigned by OREDA for this and the same will be binding on the bidders.

Chief Executive

I/we have carefully read & understood the above terms & conditions of the bid & agree to abide by them.

Signature of Bidder with Sea

7. Commercial Terms & Conditions

7.1. Rate:

The offer should indicate the unit cost of the system, Installation & Commissioning charges, CMC Charges and taxes & duties. The unit cost must be inclusive of packing, forwarding, loading & unloading charges, taxes & duties ,cost of insurance and transportation FOR any destination in the state of Odisha.

7.2. Sales Tax & Duties etc

All Taxes and duties as prescribed both under Central and State Government sales tax rules would be applicable.

7.3. Earnest Money Deposit

- i. Earnest money deposit as specified is required to be deposited along with the bid without which the bid will not be accepted. No interest will be payable for the EMD amount under any circumstances.
- ii. Earnest money should be deposited in shape of a Demand Draft in favour of Chief Executive, OREDA from any Nationalised Bank Payable at Bhubaneswar and the proof of deposits should be attached to the bid.
- iii. EMD would be refunded to the unsuccessful Bidders after finalization of the bid without any interest.

- iv. EMD would be refunded to successful bidder(s) after submission of security deposit as detailed at clause 7.4.
- v. EMD would be forfeited if:
 - a) any bidder withdraws his bid or resiles from his offer during the validity period.
 - b) The successful bidder fails to furnish his acceptance of the order within 15 days of placement of work order/LOI/LOA.
- vi. The bidder fails to successfully complete the work within the stipulated time. Delay in completion due to extreme and unavoidable situation shall have to get approved by the Chief Executive, OREDA. This approval shall have a cut-off date by which the entire shall have to be completed.
- vii. In case of claim for exemption from deposition of Earnest money sufficient proof in support of claim for exemption of EMD as prescribed in Govt. of India Notification is to be attached with the bid.

7.4. Security Deposit

The successful bidder must deposit the Security amount @ 10% of the ordered value with the Chief Executive, OREDA, Bhubaneswar-10 at the time of acceptance of the work order in shape of Bank Guarantee. The Security Deposit will be refunded after successful testing, commissioning, and handing over the project to the user.

7.5. Performance Guarantee

Following successful testing, commissioning and handing over and prior to release of final instalment of payment the bidder is required to deposit performance guarantee @10% of the ordered value in shape of Bank Guarantee to OREDA from the date of acceptance of the work order or till the completion of respective warranty periods whichever is later. The said deposit would be forfeited, if the systems are not maintained as per the terms of reference of the rate contract. PBG will be refunded after the expiry of the Warranty period and CMC period (ref. clause 2 of Scope of Work) of the systems, subject to satisfactory performance of the systems.

7.6 Allocation of work:

All successful bidders conveying acceptance to L1 price for Solar water heating system under this tender shall be duly empanelled and arranged in the order of their quoted prices as L1, L2, L3,Ln.

Depending upon the quantum of materials required as well as the geographical spread of the installations the first batch of the order will be placed on one or more empanelled bidders basing on the order of their empanelment.

Placement of subsequent orders on the same bidders will be subject to timely execution and performance in respect of the previous work order.

Placement of subsequent work orders on bidders who have not received any order will be subject to the quantum of materials required as well as geographical spread of the work.

Business generated by the firm at its own will be entitled to get approval/ order from OREDA to execute the project at L-I price.

The decision of Chief Executive, OREDA in this regard shall be final and binding.

7.7. Programme Execution Schedule

- i) Delivery of systems at sites: 2 months from the date of issue of the purchase order
- ii) Installation & Commissioning 3 month from the date of preliminary inspection, physical verification and handing over of systems for installation
- iii) Upon intimation about commissioning of the systems by the executing firm a joint inspection will be carried out by the representatives of the executing firm, OREDA and the authorised representative of the user organization. Following such inspection a joint commissioning report shall be brought out in the prescribed format, which shall form a part of the documents for release of payments. This certificate shall be issued within 30 days of intimation from the executing firm
- iv) The issuance of a JCC shall, in no way relieve the executing firm of its responsibility for satisfactory operation and maintenance of the solar thermal systems.

7.8 .Quantity

The quantities of Solar water heating systems will be subject to the orders placed by various user organization/ individual beneficiary..

7.9. Validity of offer

The offer must be kept valid for a period of one year from the date of opening of the technical bid. No escalation clause except the admissible tax component under the period of consideration would be accepted. The validity can be further extended with mutual consent.

7.10. STCC/ VAT

The bidders must submit attested copy of valid up to date sales Tax / VAT clearance certificate along with the bid. The bid would not be considered without this document. The original certificate would be produced at the time of opening of the bid, or, before placement of purchase order, if required.

7.11. Warranty

The Solar water heating system & HDPE tank with supporting structure should be warranted against any manufacturing defect or bad workmanship for a period of 5 (five) years from the date of commissioning of the systems.

Warranty certificate to the above effect must be furnished along with the commissioning reports.

Any defect noticed during warranty period should be rectified/replaced by the supplier free of cost upon due intimation to the user / OREDA . The warranty period shall be extended by the period during which the systems remain non-operative due to reasons within the control of the executants. Care should be necessarily taken to make the system operational within a week of reporting of defect. If the system is not made operational within fifteen days, OREDA may rectify the same and charge all expenses incurred on the said account to the vendor.

7.12. Penalty and termination of contract

The systems shall be supplied, installed and commissioned within the scheduled time. If the supplier fails to adhere to the schedule, OREDA shall without prejudice to its other remedies under the contract deduct from the contract price as liquidated damages a sum equivalent to 1% of the delivery price of the delayed goods or unperformed services for each week of delay until actual delivery or installation/commissioning up to a maximum deduction of 10% of the contract price for delayed goods or installation and commissioning. Once the maximum is reached (i.e 10 weeks of delay) OREDA may consider termination of the contract and forfeit the security deposit without prejudice to the other remedies of the contract along with recovery of mobilization advance by forfeiture of bank guarantee.

However, Chief Executive, OREDA may at his own discretion allow reasonable time extension upon written application of the supplying firm. If the delay is considered intentional or due to negligence of the vendor extension can be allowed with imposition of penalty. If the delay is considered to be genuine time extension can be allowed without imposition of penalty.

7.13. Force Majeure

The supplier of the system shall not be charged with liquidated damages nor shall his security for performance be forfeited when failure of the supplier in making delivery is due to any event beyond the control of the supplier and could not have been foreseen, prevented or avoided by a prudent person. These include, but are not restricted to acts of God, acts of public enemy, acts of Government, fires, floods, epidemics, strikes, freights, embargoes and unusually severe weather.

7.14. Inspection

- i. All tests and inspections shall be made at the place of delivery unless otherwise specifically agreed upon by the bidder and OREDA at the time of purchase. Authorized OREDA Officer shall be entitled at all reasonable time to inspect and supervise and test during erection and commissioning. Such inspection will not relieve the executing firm of their obligation in the contract.
- ii. OREDA has the right to have the tests carried out at its own cost by an independent agency at any point of time. Pre- delivery inspection at the factory site if necessary will be carried out by OREDA.

7.15. Payment

Payment for the work (excluding CMC charges) under normal circumstances will be done as detailed below;

- i) **First Interim Payment @ 75%** of the total value of order (excluding AMC charges) after commissioning of the project. The check list of documents to be submitted with the bills for release of first instalment is annexed at Annexure- D

- ii) **Second interim payment @ 25%** of the total value after successful functioning of the system for six months. Submission of all documents as per check list given at Annexure E

7.16. Execution

Execution of work shall be carried out in an approved manner as outlined in the technical specification or where not outlined, in accordance with relevant Indian Standard Specification, to the reasonable satisfaction of the Authorized OREDA Officer.

7.17. Comprehensive Maintenance Contract

CMC will be applicable from the date of commissioning of the system. The bidder must enter into a Comprehensive maintenance contract for the specified period before release of the first instalment of payment. Offer without such CMC shall not be considered. The scope of CMC must cover supply of spare parts / services during the contract in force. Order shall be placed only on bidders who agree to offer such CMC. The CMC charges quoted by the bidder must be realistic in view of actual rendering of after sale services. Bids with very low/unrealistic CMC charges will be liable for rejection. The payment of annual maintenance charges under the Comprehensive Maintenance Contract shall depend upon the functionality of the system duly certified by the concerned office/ Authorised officials of OREDA. Upon receipt of such certificates CMC amount as applicable shall be paid at the end of 1st, 2nd, 3rd, 4th and 5th years. (Format to be issued to the successful bidder only)

7.18. Limitation of Liability

OREDA, will, in no case be responsible for any accident fatal or non-fatal, caused to any worker or outsider in course of transport or execution of work. All the expenditure including treatment or compensation will be entirely borne by the Executants. The Executants shall also be responsible for any claims of the workers including PF, Gratuity, ESI & other legal obligations.

7.19. Dispute

For adjudication of any dispute between OREDA and the bidders arising in this case, reference can be made to any Law courts under the jurisdiction of Orissa High court only. The Chief Executive, OREDA reserves the right to accept or reject any or all bids without assigning any reason thereof.

Chief Executive

OREDA

I/We have carefully read and understood the above terms and conditions of the bid and agree to abide by

SIGNATURE OF BIDDER WITH SEAL

A. TECHNICAL SPECIFICATIONS FOR SOLAR WATER HEATING SYSTEM

specification

FLAT PLATE SOLAR WATER HEATING SYSTEM

The solar water heating system of 100 - 3000 LPD capacity at 60 ° will be installed any location in the state of Odisha.

STANDARDS

The details of the standard which contain minimum performance requirement along with the test method are as follows.

1. Solar Flat Plate Collector

- a) IS 12933 (Part-1): 2003 , solar flat plate collector – Specification , part 1-requirement
- b) IS12933 (Part-2) :2003 , Solar flat plate collector-Specification, Part-2-Components
- c) IS 12933(Part-3) :2003 Solar flat plate collector –Specification ,part-3- Measuring Instruments
- d) IS 12933 (Part-5) :2003 , Solar flat plate collector-Specification, part-5-
- e) test method

2. MNRE Specification for test procedure

Test procedure for Thermo-syphonic solar water heating systems are available on MNRE web site www.mnre.gov.in should be followed.

Test Report & Testing laboratory /center

The Solar Collector must be tested at any test centers in the country which is recognised by BIS for carrying out certification testing for solar water heating system as per Indian Standard. Only Collector as per BIS specification No- 12933 solar flat collector and also BIS marked will be supplied.

SOLAR WATER HEATING SYSTEM

- i. Natural Circulation (Thermo syphon) and
- ii. Pressurized system
- iii. Forced circulation system

Capacity & Temperatures: 100 LPD to 3000 LPD and 60 degree C

Sl. No.	Item and Specifications	Natural Circulation (Thermo syphon)
1.	Supply of collectors and stand with installation	As per system capacity
	Absorber: cu-cu only: Box	
	Aluminium (ISI Mark only) IS: 12933	
2.	Supply and installation of insulated storage tank with stand	Capacity same as per system capacity
	Material of construction	Stainless steel – 316
	Insulation with thickness of material	Rock wool 100 mm / PUF 50 mm upto 2000 LPD system. For system above 2000 LPD rock wool 130 mm/ PUF 75 mm
	Density of insulation	Rock wool – 48 Kg / m ³
		PUF-40 Kg /m ³
	Insulation cover	Aluminium sheet 22 swg.
3.	Supply control instruments with installation.	1-set for each system
	<ul style="list-style-type: none"> • Tap (brass Tap) 	1 No.
	<ul style="list-style-type: none"> • Gate Valve (Brass, 1 inch, ISI Mark) 	2nos.
	<ul style="list-style-type: none"> • Non return valve (ISI mark) 	1 No.
	<ul style="list-style-type: none"> • Air vent 	1 No.
	<ul style="list-style-type: none"> • Strainer (ISI Mark) 	1 No.
	<ul style="list-style-type: none"> • Temperature Gauge ISI mark 	1 No. For above 500LPD system

Other requirement of water heating system

1. Overall dimension of collector

Size	Length (in mm)	Height(in mm)	Width(in mm)
A	1860± 10	100±10	1240± 10
B	2120 ± 10	100± 10	1040± 10
C	2050± 10	100± 10	930± 10

2. **Cover plate :-** The cover plate shall be single piece tempered / toughened glass and minimum of 4 mm thick ,free from bubbles and rough surface as per the latest BIS specification ((IS: 12933 part-2: 2003)The solar transmission of the cover plate shall be minimum 82% at near normal incidence.

3. **Collector Box:** - The collector box shall be made of aluminium section only. Type, grade, size, workmanship and finish of the material used shall be as per latest BIS specification. The minimum thickness of Aluminium shall be as under.

Channel Section for sides	1.6mm
Sheet for bottom	0.7mm
Support for glass retaining	1.2mm
Sheet for entire body	1.0mm

4. **Absorber:-**The absorber consists of risers, headers and sheet for absorber.

(a) Material :- Copper sheet and copper tubes

(b) Thickness :- 34 SWG (IS-191)

(c) Copper tubes (Riser) : Diameter = 12.7 mm(± .5mm)

Thickness =24 SWG (IS-2501)

(d) Header Diameter = 25.4 mm (±.5mm)

Thickness = 22 SWG

Projection = 40mm (± .5mm) outside the collector box including the flanges.

(e) Space between riser tube: Maximum 12 cm from center to center of the riser.

(f) Bonding between riser and sheet.- Full length of all risers shall be welded with absorber sheet. In case of brazing / soldering /TIG welding of continuous nature, unbrazed /unsoldered portion should not exceed more than 10 % of the length of the riser . For brazing /soldering, minimum 60% tin solder or suitable brazing material shall be used. The flux used for soldering /brazing shall be non greasy.

(g) Header- riser joints:- The assembly of riser with the header shall ensure the tube protrusion inside the header not exceeding 3mm. The riser shall be brazed /welded with header.

(h) Absorber coating: - In all systems selective coating shall be used. The selective coating shall have emissivity <0.2 and absorptivity> 0.92.

- (i) Absorber area:- 2 sqm per 100 LPD at 60 °C ..
5. **Testing of riser –Header:** - Riser and header assembly designed for working pressure up to 245 kPa (2.5 Kg/cm²) shall be tested for leakage at a minimum hydraulic pressure of 490 kPa (5Kg/cm²) . The system designed for higher pressure than 245 kPa, the assembling shall be tested at a pressure twice the designed pressure.
6. **Collector box installation:-**
- (a) Back & side insulation: - Minimum 50mm thick insulation of rock wool/ glass wool/ mineral wool shall be provided. Thermal resistance of insulation materials shall be minimum 0.96 square meter ° C /W for back insulation and minimum 0.48 square meter° C /W for side insulation. The collector box insulation shall conform to latest BIS specification. (IS 3346).
- (b) Aluminium foil of thickness of .016 mm ± 0.005 mm shall be used for covering the back as well as side insulation.
- (c) Back and side insulation shall withstand at 175°C.
7. **Gaskets and grommets:** - The load of the absorber should not be on the insulation. It should be taken by the collector box. Insulation should not be allowed to slide. Gasket used for sealing the glass with collector box may be of Neoprene / Silicon/EPDM rubber channel section. Grommets for sealing the collector box and the header joint may be one of the following types and shall fit properly so that no dust can pass through the joints:
- a) Neoprene rubber,
b) EPDM,
c) Silicon rubber
- Grommet and gaskets shall be capable of withstanding temperature up 125° C and shall conform to thermal shock test.
8. **Header flanges:** -Copper/brass flanges of 62mm ± 3mm diameter and minimum thickness of 4mm with provision for 4nos of brass nut and bolts with diameter of 5mm - 6mm shall be used. Flanges shall be brazed to header and brazing tested for leakage to test pressure. In no case crude solder flanges shall be used. Assembly of the flanges should be at right angle to the header area to ensure proper assembly at the side of the insulation.
9. **Assembly of the Collector:-**
- a) The collector shall be assembled in such a way that the weight of the absorber is distributed uniformly on the side wall of the collector box.
- b) The entire assembly shall be free from surface defects. All sharp edges and corners shall be rounded off. The exposed surfaces shall be properly made corrosion resistant.
- c) The air gap between the cover plate bottom and the absorber surface shall be within 20mm to 40mm.
- d) The glass should be firmly held, without strain taking in to account the expansion of glass. Top surface along with the edge between the glass and the aluminium angle shall be caulked with suitable sealant such as zinc oxide based or rubber based or silicon rubber based or epoxy based compound.
- 10 Gasket for Flanges:-**3mm thick compressed asbestos fibre or Neoprene rubber gasket shall be used for sealing the joints between flanges.

11. Collector Support frame: -The structure shall be in a position to withstand wind velocity of 200 Km/hr. The structure shall be made with angle iron stronger than 35mm X 35mm X 3mm and shall have the vertical support at top and bottom edge of the inclined plane of the collector at a distance of 2.5 m or less. The vertical support shall be firmly grouted to the roof or in the ground in case of ground mounted system. The grouting blocks shall be minimum 30cm X 30cm X 30cm and finished properly. In case of grouting is carried out on a roof already water proofed with asphalt , the back support of the collector may be anchored to the parapet or the size of the grouting block shall be increased to provide for a dead load weight anchoring of 75 Kg per leg of the vertical stand.

The collector `support frame shall be rectangular shape i.e having all four sides touching the collector edge. The cement pedestals should be made after chipping of the existing rooftop to provide proper gripping and strength. Structure should be such that collector's bottom side is at least 30 cm above the ground/roof level. In case of inclined roof, the collector housing frame along with the vertical angle shall be mounted & fixed using suitable necessary structure keeping in view the load bearing capacity of the roof top ensure the stability against storm. The collector should be properly clamped and tightened with frame and supporting structure at both the ends by 20mmX 2mm size MS strip consisting rubber packing to avoid chemical reaction between the collector bodies and clamp. Last row of collector supporting structure should be grouted throughout its length opposite to collector facing with c.c work ratio 1:2:4 of size 30cm X 30cm X 30cm (d x h i.e height X width) and then plaster with cement.

12. Painting of stand: -Proper cleaning and degreasing of the surface should be done before painting. Two coats of zinc chromate red oxide primer shall be applied followed by one coat of enamel paint. Suitable anticorrosion paint should be applied after proper treatment.

13. STORAGE TANK

a) Material : De-Pressurized

The tank shall be made up of stainless steel (SS304/316).

The storage tank for 100/ 200 litres capacity shall be made of 22 SWG stainless steel only. Above 200 and up to 500 litres capacity the storage tank shall be of stainless steel of thickness 20 SWG, above 500 and up to -1500 litters, it shall be of 16 SWG, above 1500 and up to 3000 litters, it shall be of 14 SWG .Support structure shall be designed properly to withstand the load of the Storage Tank, wind speed and the stored water. Sucket and internal fittings should be stainless steel

b)Material: Pressurized @ 3.5 kg/cm³

The tank shall be made up of stainless steel (SS-304/316).

The storage tank for 100 /200 litres capacity shall be made of 16 SWG stainless steel only.

Above 200 and up to 500 litres capacity the storage tank shall be of stainless steel of thickness 14 SWG, above 500 and up to 1500 litres, it shall be of 12 SWG, above 1500 and up to 3000 litres, it shall be of 10 SWG and for capacity more than 3000 litres, it shall be with proper stiffening & withstanding strength.

Support structure shall be designed properly to withstand the load of the Storage Tank, wind speed and the stored water. Sucket and internal fittings should be stainless steel

c) Forced circulation system

The tank shall be made up of stainless steel (SS-304/316). The storage tank for 3000 liters, it shall be of 14 SW and for capacity more than 3000 liters, it shall be of 10 SWG thicknesses or more with proper stiffening.

For 3000LPD systems the supplier should provide Solar circulation pump and control unit as per the site condition.

Support structure shall be designed properly to withstand the load of the Storage Tank, wind speed and the stored water. Sucket and internal fittings should be stainless steel

Insulation: - Insulation should withstand temperature of 100 ° C. Thin polythene sheet shall be used as covering between the glass wool and the cladding sheet besides the retaining materials such as chicken mesh etc. Aluminium sheet of thickness, 22 SWG / GI sheet of minimum 24 SWG shall be used for cladding the tank insulation. External of the tank should be properly insulated so that hot water temperature does not decrease by more than 5 degree C in about 16 hours times.

The storage tank shall be properly installed at site using enamelled coat appropriate size angle iron stand, girder cement pedestals of 1:2:4 ratio or any other specific provision suitable to site to ensure the stability against heavy storm etc.

14. Piping:-

½ inch to 2 inch dia ISI marked GI pipe , medium class of IS 1239 shall be used for piping. 50 mm thick rock wool insulation of 48 Kg/cum density be used for hot water pipes. Thin plastic sheet shall be used as covering between rock wool and aluminium cladding besides other retaining materials like chicken mesh etc. 26 SWG thick aluminium sheet shall be used for cladding the insulated pipe. The pipe line should be properly supported and fixed with clamp with the help of suitable size stand/civil structure (cement concrete ratio 1:3: 4). ISI mark gunmetal strainer of standard make should be fitted in the main cold water supply line before the system. ISI mark **CPVC pipes and fittings can be used in hot water line .**

15. Valves/Nipple/tees/bend/taps:-

Gunmetal valve as per ISI specification shall be used. Nipple/tees and bends shall be of medium class G I (B-class) /brass or copper. Gunmetal valve in each row shall be provided. TAPS of stainless steel ISI mark or reputed make shall be provided. Good quality CPVC fittings can also be used of appropriate sizes.

16. Temperature gauge:-

Temperature gauge (ISI mark):- One for hot water storage tank/outlets – dial type – duly calibrated and suitable for temperature ranges (0 to 120 ° C)

A. TECHNICAL SPECIFICATIONS FOR HDPE TANK

Sl No	Maximum capacity(in liter)	Overall Diameter in MM	Overall Height in MM	Minimum Internal Dia of Man hole/hand hole in MM	Minimum Wall and bottom thickness in MM	Minimum Weight of tank
1	200	650-850	490-690	265	3	7.8
2	300	650-850	700-900	265	3	9.0
3	400	700-980	700-950	265	3.5	15.0
4	500	800-1140	625-1025	370	4	18
5	1000	1000-1200	1050-1350	370	4.5	33

The stand should be of MS. Proper cleaning and degreasing of the surface should be done before painting. Two coats of zinc chromate red oxide primer shall be applied followed by one coat of enamel paint. Suitable anticorrosion paint should be applied after proper treatment. The supporting structure should be grouted with c.c work ratio 1:3:4 of size 30cm X 30cm X 30cm (d x h i.e height X width) and then plaster with cement. The structure shall be in a position to withstand wind velocity of 200 Km/hr..

The support frame shall be rectangular shape. The cement pedestals should be made after chipping of the existing rooftop to provide proper gripping and strength.

Drawing For structure

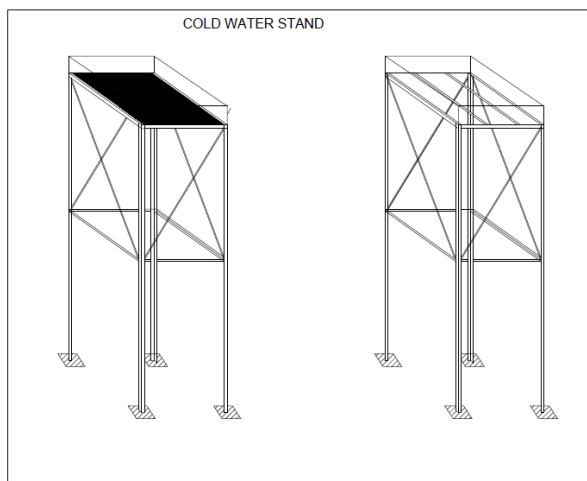

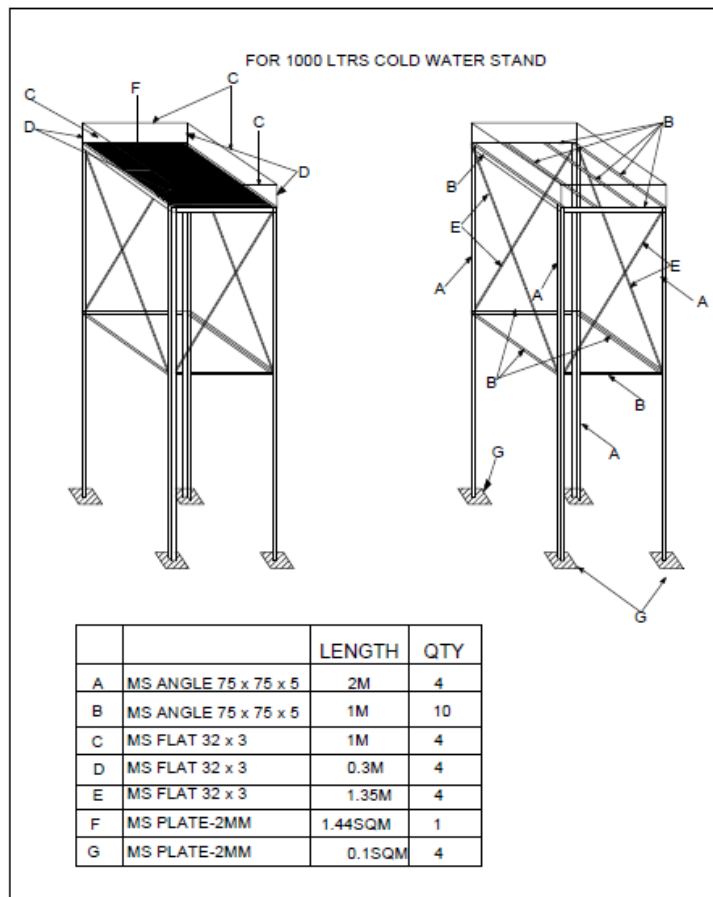
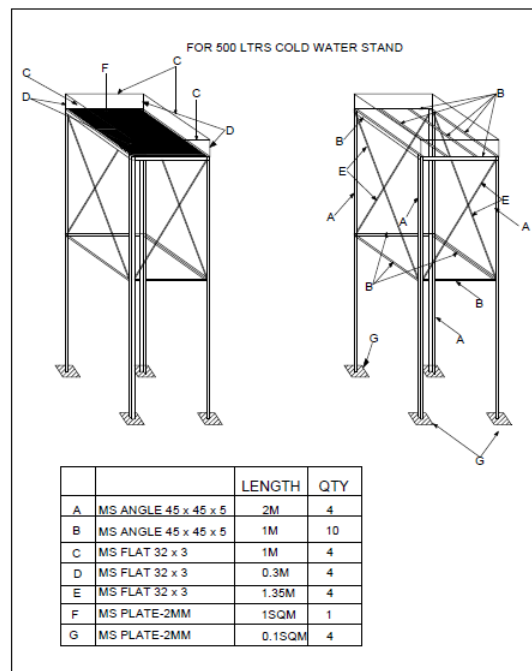
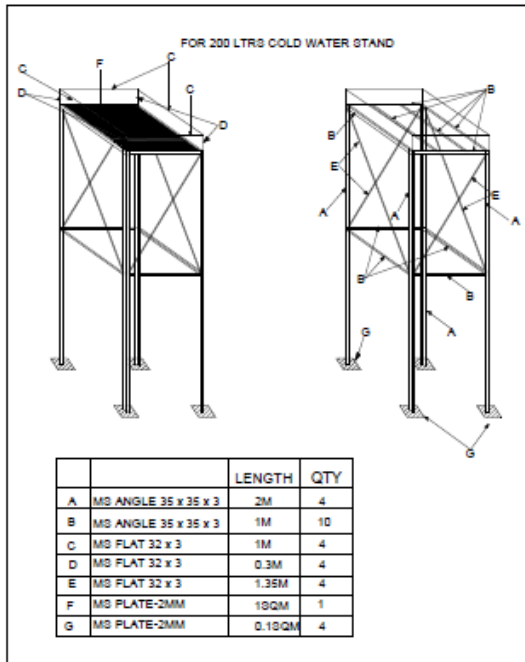

FOR 300 LTRS COLD
WATER STAND

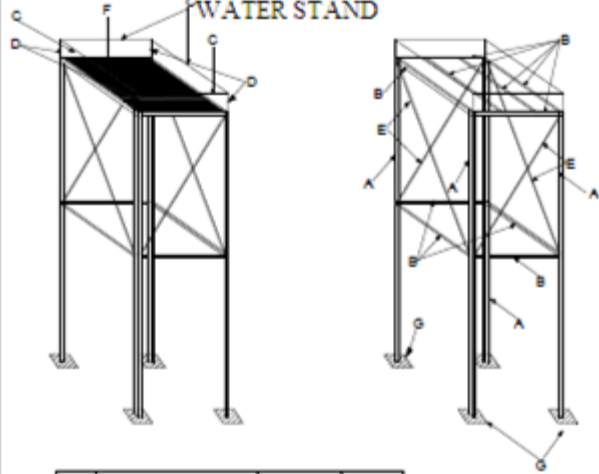

		LENGTH	QTY
A	MD ANGLE 35 x 35 x 3	2M	4
B	MD ANGLE 35 x 35 x 3	1M	10
C	MD FLAT 32 x 3	1M	4
D	MD FLAT 32 x 3	0.3M	4
E	MD FLAT 32 x 3	1.35M	4
F	MD PLATE-2MM	10QM	1
G	MD PLATE-2MM	0.10QM	4

PRICE BID

Sl. No.		Name of the Systems	Total Rate in Figures (Per No.) including all taxes & duties		CMC cost for five years including all taxes & duties	
			For Soft Water	For hard Water	For Soft Water	For hard Water
	a	Natural Circulation (Thermo syphon)				
	i.	100 LPD				
	ii.	200 LPD				
	iii.	500 LPD				
	iv.	1000 LPD				
	v.	1500 LPD				
	vi.	2000 LPD				
	vii.	2500 LPD				
	viii.	3000 LPD				
	B	Pressurised System	For soft water	For hard water	For Soft Water	For hard Water
	i.	100 LPD				
	ii.	200 LPD				
	iii.	500 LPD				
	iv.	1000 LPD				
	v.	1500 LPD				
	vi.	2000 LPD				
	vii.	2500 LPD				
	viii.	3000 LPD				
	C	Force Flow Circulation System	For soft water	For hard water	For Soft Water	For hard Water
	i.	3000 LPD				

SIGNATURE & SEAL OF BIDDER

PRICE BID

Sl. No.		Name of the Systems	Total Rate in figures including plumbing charge and all taxes & duties.	
	A	Cold water supply pipe with required fittings	For GI/meter with all fittings	For CPVC / meter with all fittings
	i.	½ inch		
	ii.	¾ inch		
	iii.	1 inch		
	iv.	1¼ inch		
	v.	1½ inch		
	vi.	2 inch		
	vii.	2½ inch		
	B	Hot water supply pipe with required fittings	For GI/meter with all fittings and insulation	For CPVC / meter with all fittings
	i.	½ inch		
	ii.	¾ inch		
	iii.	1 inch		
	iv.	1¼ inch		
	v.	1½ inch		
	vi.	2 inch		
	vii.	2½ inch		

SIGNATURE & SEAL OF BIDDER

Price bid

Annexure- C- (i)

Sl no	Item	Rate
1	Supply, installation of 200 LPD HDPE cold water tank (ISI mark) with float valve & hot dipped GI coated M/S support structure	
2	Taxes & duties on item no- 1	
3	Total (item no- 1 + 2)	
4	Transportation, installation of cold solar water tank with sand .	
5	Taxes & duties on item no- 4	
6	Total (item no- 4+5)	
10	Grand total (item no- 3+6)	

SIGNATURE & SEAL OF BIDDER

Annexure- C-(ii)

Sl no	Item	Rate
1	Supply, installation of 300 LPD HDPE cold water tank (ISI mark) with float valve & hot dipped GI coated M/S support structure	
2	Taxes & duties on item no- 1	
3	Total (item no- 1 + 2)	
4	Transportation, installation of cold solar water tank with sand .	
5	Taxes & duties on item no- 4	
6	Total (item no- 4+5)	
10	Grand total (item no- 3+6)	

Annexure- C- (iii)

Sl no	Item	Rate
1	Supply, installation of 500 LPD HDPE cold water tank (ISI mark) with float valve & hot dipped GI coated M/S support structure	
2	Taxes & duties on item no- 1	
3	Total (item no- 1 + 2)	
4	Transportation, installation of cold solar water tank with sand .	
5	Taxes & duties on item no- 4	
6	Total (item no- 4+5)	
10	Grand total (item no- 3+6)	

SIGNATURE & SEAL OF BIDDER

Annexure- C- (iv)

Sl no	Item	Rate
1	Supply, installation of 1000 LPD HDPE cold water tank (ISI mark) with float valve & hot dipped GI coated M/S support structure	
2	Taxes & duties on item no- 1	
3	Total (item no- 1 + 2)	
4	Transportation, installation of cold solar water tank with sand .	
5	Taxes & duties on item no- 4	
6	Total (item no- 4+5)	
10	Grand total (item no- 3+6)	

SIGNATURE & SEAL OF BIDDER

ANNEXURE-D

Check List for submission of information/documents after commissioning of the project

S/N	Information/document to be submitted	Whether submitted
1	Site Details Name of the location Postal Address Phone No. Fax No. Name of the OIC/Contact Person	
2	System details a. Solar Collector Make- Year of manufacturing test report from MNRE authorised test centre Serial Number b. Hot water tank Make Model Yr of manufacturing Serial Number – c. Cold water tank if installed Make Model Yr of manufacturing Serial Number –	
3	Warranty/ Guarantee of the composite system	
4	Training details Date of training No. of persons trained Name & designation of the persons	
5	Service Centre Details Name /address / contact details of the service centre that will cover the project Name & mobile No. of the person of the service centre in-charge of the project	

Annexure E

SRI No.	Document to be submitted	
1	Joint commissioning & system handing over report (in prescribed format)	
2	Signed Copy of CMC	
5	Performance report after six months of daily/monthly wise output / consumed with proper reason in case of short fall.	

ANNEXURE- F

**ORISSA RENEWABLE ENERGY DEVELOPMENT AGENCY
S-59, MANCHESWAR INDUSTRIAL ESTATE,
BHUBANESWAR-751010
FORMAT FOR WARRANTY CARD**

1. Name & Address of the Manufacturer/Supplier of the System	
2. Name & Address of the place	
3. Date of installation of the system	
4 Details of Solar Collector (s) supplied in the system Make (Name of the manufacturer) Model Serial No. (s) Warranty valid up to	
5 Details of HDPE TANK & STAND (s) supplied in the system Make (Name of the manufacturer) Capacity Warranty valid up to	
6 Designation & Address of the person to be contacted for claiming warranty obligations.	

(During the warranty period MNRE / OREDA authorized Officer / Users reserves the right to cross check the performance of the system as per the minimum performance levels specified.)

Signature & Stamp

VENDOR

Place:

date:

Forwarding Letter
(to be submitted in the letter head of the bidder)

To,

The Chief Executive
Odisha Renewable Energy Development Agency (OREDA)
S.59, MIE, Bhubaneswar -751010
Odisha

Subject: Tender for Standard Rate Contract for Design, Supply, Installation, Commissioning and Maintenance for a period of 5 years of solar water heating system of various capacities in the state of Odisha vide tender call Notice **No2241 OREDA dated 03-10-2015.**

Sir,

Having studied the Tender document carefully I/we, the undersigned, offer to submit our tender for the work of Design, Supply, Installation, Commissioning and Maintenance for a period of 5 years of Solar Water heating system of ----- capacities in conformity with the aforementioned tender document.

I/We have also read the various provisions of the Tender and confirm that the same are acceptable to us including the provision of CMC. We further declare that any additional conditions, variations, deviations, if any, found in our Tender offer shall not be given effect to. We further understand that **any deficiency / illegibility in documents shall make our tender liable for rejection.**

I/we submit our tender understanding fully well that

- (a) The bid and other documents submitted along with the same will be subject to verification by appropriate authorities.
- (b) OREDA reserves the right to accept or reject any application or the bid process itself without assigning any reasons thereof and shall not be held liable for any such action.
- (c) Any genuine changes made by OREDA in the interest of the work with respect to the technical requirement during the course of project execution will be acceptable to us.

We hereby declare that all the information and statements made in this proposal are complete, true and correct and also accept that any misinterpretation contained in it may lead to our disqualification.

We hereby declare that our Tender is made in good faith and the information contained is true and correct to the best of our knowledge and belief.

Yours faithfully,

Signature of bidder

UNDERTAKING BY THE BIDDER

I/we here by undertake that

1. We have thoroughly read and examined the notice inviting tender and the tender document along with all its schedules, annexure etc.
2. The rates quoted by us are firm and final and are meant for execution of the allotted work within the time frame stipulated in the tender/work order.
3. All terms and conditions of the tender including the rates quoted by us shall remain valid for a period of one year.
4. In case our tender is incomplete in any respect or we violate any of the prescriptions given in the tender for submission of the same OREDA shall , without prejudice to any other right or remedy , be at liberty to forfeit the earnest money deposited by us.
5. In case of award of work in our favour OREDA shall have the right to convert the EMD deposited by us in to full or part (as the case may be) of the security deposit to be deposited by us against award of the work.
6. In case we fail to commence or complete the work as per the time schedules or fail to fulfil any of the terms and conditions given in the tender OREDA shall , without prejudice to any other right or remedy , be at liberty to forfeit the security deposit made by us against the award of the work.
7. I/We hereby declare that I/We shall treat the tender documents, specifications and other records connected with the work as secret/confidential and shall not communicate information derived there-from to any person other than a person to whom I/We have authorized to communicate the same or use the information in any manner prejudiced to the safety of OREDA/the State Govt.
8. I/We shall abide by all the laws prevailing at the time of the execution of the work and shall be responsible for making payments of all the taxes, duties, levies and other Govt. dues etc. to the appropriate Govt. departments.
9. Our state commercial tax / TIN registration no. is _____ and
CST registration No. _____.

- The PAN No. under the Income Tax Act is _____ and
Service Tax Registration No. is _____.
10. I/We shall be responsible for the payment of the respective taxes to the appropriate authorities and should I/we fail to do so, I/we hereby authorize OREDA to recover the taxes due from us and deposit the same with the appropriate authorities on their demand.

Signature of bidder with stamp

Dated:

Letter of Authorization

(to be submitted in the letter head of the bidder)

To,
Chief Executive
Odisha Renewable Energy Development Agency
S-59, MIE, Bhubaneswar-751010
Odisha

Sub: Submission of Tender for Standard Rate Contract for Design, Supply, Installation, Commissioning and Maintenance for a period of 5 years of solar water heating system of various capacities in the state of Odisha

Ref: Tender call Notice No2241OREDA dated03-10-2015.

Sir,

I/we hereby authorize Ms. /Mr. _____ , Designationof our company to sign all relevant documents on behalf of the company/firm in dealing with the above tender. She / He is also authorized to attend all meetings and submit technical and commercial information as may be required by OREDA in the course of processing of the tender.

We further authorize Ms. /Mr. _____ designation..... of our company to make technical presentation on behalf of the company.

Signature of the authorized persons

1. _____
2.

Signature attested

Name and designation of the attesting officer with stamp

Yours faithfully
Head of the organization

DECLARATION

(to be submitted on the letter head of the company)

To,

Chief Executive
Odisha Renewable Energy Development Agency
S-59, MIE, Bhubaneswar 751 010.
Odisha

Sub: Submission of Tender for Standard Rate Contract for Design, Supply, Installation, Commissioning and Maintenance for a period of 5 years of solar water heating system of various capacities in the state of Odisha

Ref: Tender call Notice No 2241/OREDA dated 03-10-2015.

Sir,

I/we hereby declare the following in the context of the aforementioned tender that:

- a) The entire tender document has been discussed in the Board meeting and a resolution has been concurred for participation in the tender (copy enclosed)
- b) We are not involved in any litigation that may have an impact of affecting or compromising the delivery of services as required under this tender
- c) We are not blacklisted / defaulted in any manner by any Central / State Government / Public Sector Undertaking in India.
- d) In case any false documents submitted and found any time in future the firms shall be liable to be proceeded against as per prevailing laws.

Yours faithfully,

Authorised signatory

(Stamp)