

ODISHA RENEWABLE ENERGY DEVELOPMENT AGENCY

BHUBANESWAR

BID DOCUMENT

DETAILS OF TENDER CALL NOTICE No-661. /OREDA DTD- 06-03-2017

FOR

Supply, Installation, Commissioning and Maintenance for a period of 5 years of different capacities of solar water heating system in the state of Odisha

Date of Hoisting of the bid document on Website	10.3.2017
Date & time of pre-bid meeting	23 .03..2017 on 3.00 PM at OREDA Conference hall
Hoisting date of final revised bid document	25.3.2017
Date and time of last submission of online bid document	10.4.2017 up to 1.00 P.M
Date and time of last submission of hard copy of bid document	13.4.2017 up to 1.00 P.M.
Opening of Techno-Commercial bid	13..4.2017 at 3.00 P.M.
Date of opening of the price bid	To be informed to the technically qualified bidders.

S-3/59, MANCHESWAR INDUSTRIAL ESTATE, BHUBANESWAR-751010

Phone: (0674) 2588260,2586398,2580554, Fax:2586368

Website: www.oredaorissa.com Email: ceoreda@oredaorissa.com

INDEX

Sl No	Items	Page
1	Disclaimer	3
2	Details of Notice inviting e-tender	4
3	Scope of work	5
4	Important information	5
5	Submission of Bid	8
6	Undertaking by Bidder	16
7	Letter of Authorization	17
8	Declaration	18
9	Eligibility Criteria	19
10	Acceptance/Rejection of Bid	19
11	Commercial Term & Condition	19
12	Work Execution Schedule	20
13	Allocation of supply/installation& Execution	20
14	Payment	22
15	Technical Specification	24
16	Model Bank Guarantee format for Performance Security	34
17	Format for CMC	36

Disclaimer

Kindly Note:

1. This document is not transferable
2. Though adequate care has been taken for preparation of this document, the bidder shall satisfy himself that the document is complete in all respects. Intimation of any discrepancy shall be given to this office immediately. If no intimation is received from any bidder on the pre bid meeting or within ten days from the date of issue of the bid document, it shall be considered that bid document is complete in all respects and has been received by the bidder.
3. The Odisha Renewable Energy Development Agency (OREDA) reserves the right to modify, amend or supplement this bid document keeping in view the necessity in implementation of the scheme.
4. While the bid document has been prepared in good faith, neither OREDA nor their employees or advisors make any representation, warranty, express or implied or accept any responsibility or liability, whatsoever, in respect of any statements or omissions herein, or the accuracy, completeness or reliability of information, and shall incur no liability under any law, statute, rules or regulations as to the accuracy, reliability and completeness of this bid document, even if any loss or damage is caused by any act or omission on their part.



ODISHA RENEWABLE ENERGY DEVELOPMENT AGENCY
S-3/59, MANCHESWAR INDUSTRIAL ESTATE, BHUBANESWAR-751010
Phone :(0674) 2588260,2586398,2580554, Fax:2586368
Website: www.oredaorissa.com, Email: ceoreda@oredaorissa.com

DETAIL OF NOTICE INVITING TENDER

ODISHA RENEWABLE ENERGY DEVELOPMENT AGENCY invites e-tenders for

Supply, installation, commissioning and maintenance for a period of 5 years of Solar Water heating system as per the technical specification and description given in the tender document on standard rate contract basis in the state of Odisha.

Particulars	Earnest Money Deposit (Rs)	Tender processing fee Non refundable (in Rs.)	Non refundable Cost of Bid document (in Rs.)
Supply, installation, commissioning and maintenance for a period of 5 years Solar Water Heating system in the state of Odisha.	1,00,000	2300	10,500/-

1. SCOPE OF WORKS

- Design, supply, lifting, installation, commissioning and maintenance of Solar Water Heating System in the individual households / institution of different capacities from 100 LPD to 1000 LPD with required specification as per MNRE, GOI guideline along with other additional works required at site.
- The supplier shall after completion and commissioning of the work submit details of the same in the format.
- Comprehensive Maintenance Contract (CMC) of the solar water heating system for five years. The date of commencement of the CMC shall be reckoned from the date of commissioning of the solar water heating system.
- User may not have overhead tank at appropriate height for smooth supply of cold water to the solar water heater system. In such cases supply, installation, commissioning of ISI mark HDPE water tank with MS support Structure of different capacities from 200 liters to 1000 liters to be provided. For which specific work order will be issued in favour of successful firm for installation of such tank. The supplier is to install the HDPE tank with structure with proper civil foundation & grouting.(1:3:4).The supplier will also to connect cold water input line to HDPE tank with required fittings along with float valve and one gate valve for commissioning the project.
- The materials to be supplied to the respective sites should be as per the specification with at least five years warrantee period on the system commissioned by the firm.
- The firm shall after completion and commissioning of the work submit details of the same in the format.

2. IMPORTANT INFORMATION:

- The bids are to be submitted online only.
- Interested bidders may visit OREDA's website www.oredaorissa.com or www.tenderwizard.com/OREDA for details. **Tender documents can be viewed free of cost.**
- Bidders who want to submit bid shall have to pay the **tender cost** as mentioned in TENDER SCHEDULE. The tender cost is required to be paid in shape of **Demand draft** only, drawn in **favour of Chief Executive, OREDA payable at Bhubaneswar**. The tender cost is inclusive of VAT @ 5% and is non refundable.
- The bidders shall have to submit the non-refundable tender processing fee as mentioned in TENDER SCHEDULE, in e-payment mode only. The processing is inclusive of servicetax @15%.

NOTE: For tender processing fee to K.S.E.D.C. Ltd. Bangalore, the bidder can use various modes of e-payment facility available through Tender wizard Portal, i.e. by Credit Card, Debit Card, Net Banking).

- The bidders shall have to scan the Demand Draft towards **EMD, Tender Cost** , **signed copy of tender document (signed on all pages)** as token of unconditional

acceptance of all terms and conditions of the tender and all **other documents as required in the tender** and upload the same in the prescribed form in .pdf or .jpg format in addition to sending the originals.

- The bidders are advised to register their user ID, Password, company ID on website www.tenderwizard.com/OREDA by clicking on hyper link “**Register Me**”.
- Any clarifications regarding the scope of work and technical features of the project can be had from the undersigned during office hours
- **NB:-**All subsequent addendum/Corrigendum to the tender shall be hoisted in OREDA’s official web site www.oredaorissa.com and www.tenderwizard.com/OREDA only.

3. INSTRUCTIONS TO BIDDERS:

- Valid TIN / VAT/ Sales tax clearance certificate duly attested must be submitted along with the bid.
- The Firm must have registered under NSIC and Micro and Small Enterprises (MSEs)
- **If the bidding firm wants to participate tender as authorised dealer of any system manufacturer then the firm must submit authorisation certificate from the original system manufacturer of Solar water heating system . In such cases bidding firm’s experience, turn over and other eligibility criteria of the tender will be taken in to account for evaluation of tender .**
- Deviations in terms and conditions, Specification of material, Inspection clause etc. will not be accepted under any condition.
- The bidders should furnish the information on all past supplies and satisfactory performance.
- The bidder shall submit copies of documents defining the constitution or legal status, place of registration and principle place of business of company or firm or partnership.
- The bidder shall furnish a brief write up backed with adequate data, explaining his available capacity and experience (both technical and commercial) for the manufacture and supply of the systems, equipments within the specified time of completion after meeting all their commitments.
- The bidders shall submit reports on financial standing of the bidder such as audited profit and loss statements, balance sheets and auditor’s reports for the past, bankers’ certificates. All accounting statements submitted should be duly audited and with proper auditor’s note on accounts and accounting standards.
- Earnest money as specified in bid should be deposited shape of Demand Draft drawn in favour of the Chief Executive, OREDA payable at Bhubaneswar from any nationalized bank.
- **Bids without E.M.D will not be accepted (other than NSIC certificate holder).**

The bidding firm , claiming for EMD exemption as NSIC certificate holder, must have valid BIS test certificate issued on solar collector in favour of the bidding firm. Otherwise the bid will be disqualified.

- Hard copies of the bids received late due to postal delay or otherwise **will not be considered**.
- Since timely execution of works is of paramount importance, requests for extension of time shall not be ordinarily entertained.
- Canvassing in any manner shall not be entertained and will be viewed seriously leading to rejection of the bid.
- Certificate to the effect that the systems to be supplied are indigenous & not fully imported must be furnished.
- Power of attorney to sign the agreement on behalf of bidders & partnership deed articles, if any, should be enclosed along with original bid documents.
- Notice inviting tender, bid documents, prescribed Technical bid, price bid, terms & conditions will form the part of the tender.
- Bids will be accepted & will be opened as per information mentioned in the notice-inviting tender. No receipt against submission of bid shall be issued by OREDA.
- **If due to any reason the due date is declared as a holiday the bid will be opened on next working day at the same time.**
- All Taxes applicable at the time of supply will be admissible.
- In case of supply of any defective material or substandard material, the materials will be rejected & it will be the responsibility of the supplier for taking back & replacing the rejected materials at their own cost. In case of non-lifting of such rejected materials within a reasonable time offered by the office it will have the right to suitably dispose off the same and forfeit the amount.
- The supplied materials should strictly comply with the specifications as mentioned in the bid, otherwise the material would be liable for rejection.
- Any clarification on the technical specification and commercial terms and conditions may be clarified in writing from OREDA.
- Deviation of any commercial terms and condition and technical specification shall not be entertained under no circumstances.
- During the warranty period, MNRE/ State Agencies/ Users reserve the right to cross check the performance of the systems with the minimum performance levels specified in the MNRE/BIS specifications.
- The Chief Executive, OREDA shall award the contract to the successful bidder whose bid shall be qualified after evaluation in terms of the responsiveness and lowest rate determined on the basis price bids.
- On award of contract the qualified bidder shall be termed as contractor / supplier / executor /turnkey operator.

SUBMISSION OF BIDS:

A. MODE OF SUBMISSION OF BID:-

- i) The bidder shall submit the bid in Electronic Mode only i.e. in www.tenderwizard.com/OREDA portal. The bidder must ensure that the bids are received in the specified website as per the date and time indicated in the Tender notice.
- ii) The OREDA reserves the right to reject any bid, which is not submitted in electronic mode and according to the instruction, stipulated above.

PARTICIPATION IN e-TENDER:-

ACQUISITION OF DIGITAL SIGNATURE CERTIFICATE

- i) For all the users it is mandatory to procure the Digital Signatures of **Class III only**.
- ii) All bidders are requested to follow the following steps for registration.

REGISTRATION IN TENDER WIZARD PORTAL

- i) Log in www.tenderwizard.com/OREDA Click "Register", fill the online registration Form.
- ii) Payment for an amount of Rs. 2300/- shall be made to KSEDCL, Bangalore for vendor registration in tender wizard portal in **e-payment** mode only.
- iii) As soon as the verification is done the e-tender user ID will be enabled/provided.

ON-LINE REQUEST FOR e-TENDER DOCUMENTS

After viewing Tender Notification in www.tenderwizard.com/OREDA if bidder intends to participate in tender, he has to use his e-tendering User ID and Password which has been received after registration and acquisition of DSCs (Digital signature certificate) and to follow the instructions given below.

1. Insert the PKI (which consists of your Digital Signature Certificate) in your System.

(Note: Make sure that necessary software of PKI has been installed in your system)

2. Click / Double Click to open the Microsoft Internet Explorer
(This icon will be located on the Desktop of the computer)
3. Go to Start > Programs > Internet Explorer. Type www.tenderwizard.com/OREDA in the address bar, to access the Login Screen.
4. Enter e-tender User Id and Password, click on "Go".
5. Click on "Click here to login" for selecting the Digital Signature Certificate. Select the Certificate and enter DSC Password. Re-enter the e- Procurement User Id Password.
6. Click "Un Applied" to view / apply for new tenders.

7. Click on Request icon for online request. After making the request, bidder has to pay the requisite tender processing fee (as indicated in tender notice) through **e-payment** facility only available in the portal. Bidders will receive the Tender Documents which can be checked and downloaded by following the below steps.

- Click on the “Show form” icon.
- Tender documents will appear on the screen.
- Click “Click here to download” to download the documents.

NOTE: For vendor registration and payment of tender processing fee to KESDCL, the bidder can use various modes of e-payment facility available through Tender wizard Portal, i.e. by Credit Card, Debit Card, Net Banking.

B. ONLINE SUBMISSION OF BID

The bidders shall have to scan the Demand Draft towards **EMD, Tender Cost, signed copy of tender document (signed all pages)** as a token of unconditional acceptance of all terms and conditions of the tender and **other documents** as required for the tender and **upload** the same in the prescribed form in .pdf or .jpg format in addition to sending the original **except bid sheets (.xls)** prior to last date and time of receipt of bids as specified in tender Notice. Tender processing fees is mandatory & to be paid on **e-payment** mode as stated elsewhere in the document.

PROPER FILLING UP OF THE PRICE SCHEDULE:

- The bidder should fill up the Techno commercial and price schedule properly in the bid sheets provided in .xls format and up-load the same without changing the file name. The tender may be rejected if the schedule of price is submitted in incomplete form.

NB: The bid sheets (.xls file) shall be uploaded in www.tenderwizard.com/OREDA portal, prior to online closing of the tender. By no other means (except online) price bid shall be accepted for evaluation of tender.

- After completing all the formalities, Bidders will have to submit the tender as specified in NIT and must take care of all instructions. Prior to submission, verify whether all the required documents have been attached and uploaded to the particular tender or not.

Note down / take a print of bid control number once it displayed on the screen

- Tender Opening event can be viewed online.

(iii) Competitors bid sheets are available in the website for all participated bidders.

NOTES:

For any assistant, Contact:

E-Tendering help desk number: 080- 40482000/121/133/140 (Bangalore)

OREDA Help Desk- 91-8895911236

C. DEAD LINE FOR SUBMISSION OF BIDS

- Soft copy of the bid shall be uploaded through the portal www.tenderwizard.com/OREDA on or **before the online submission time and date as stipulated in the bidding document.**

DD towards Tender cost, DD towards EMD, tender processing fee acknowledgement & a set of all uploaded documents must be received by OREDA at the address specified not later than the time and date stated in the tender notification.

- In the event of the specified date for the submission of bids being declared a holiday for OREDA, the bids will be received on the next working day as per the time indicated in tender notification.
- OREDA may, at its discretion, extend this deadline for submission of bids by amending the Bidding Documents in accordance with Instruction to Bidders for the reasons specified therein at any time prior to opening of, in which case all rights and obligations of Employer and bidders will thereafter be subject to the deadline as extended.

D. LATE BIDS

- Soft copy of the bid will not be uploaded on the portal after expiry of submission time and the bidder shall not be permitted to submit the same by any other mode. In such case, even if the bidder has submitted the specific documents in hard copy in original (viz., EMD, tender cost & any other document) within the stipulated deadline, its bid shall be considered as late bid. The hard copy submitted [specific documents (viz., EMD, tender cost.)] shall be returned unopened to the bidder.
- Hard copy of the EMD in shape of DD if received by OREDA after the last date for submission of the bid the same will be considered as late bid even if the bidder has uploaded the soft copy of the bid within the stipulated deadline.
- In such a case, the soft part of the bid uploaded on the portal shall be sent unopened to "Archive" and shall not be considered at all any further.

E. MODIFICATION AND WITHDRAWAL OF BIDS:-

- Bidder may modify or withdraw their bids through the relevant provisions on the portal www.tenderwizard.com/OREDA **up to due date and time of submission of bid indicated in tender notification**
- The Bidders may modify and resubmit their bids as per the provisions given in the portal.
- Bidders may withdraw their bids through the relevant provisions of mentioned in

the portal.

- **No bid shall be modified/ withdrawn after the dead line for submission of bids. Withdrawal/modification of bid before the expiry of bid validity shall result forfeiture of Bidder's EMD.**

F. SUBMISSION OF HARD COPIES OF THE BIDS AND SEALING AND MARKING:-

- Along with the e-tender, bidders must also submit their bids for all items as stated above in the form of a **single hard bound** book properly page numbered and Indexed. **No loose/ separate paper or spiral bound documents will be accepted.**
- The bidders must sign at the bottom of each page of the bid documents at the time of submission in token of unconditional acceptance of the departmental terms and conditions, technical specifications etc.

Hard copies of the following items should only be submitted to OREDA

1. Demand draft towards cost of bid document
2. Copy of acknowledgement of tender processing fee.
3. EMD in shape of Demand Draft.
4. Technical Bid document in **hard bound form** with each page legibly numbered comprising of the following:
 - **BIS Test certificates in the name of the manufacturer.**
 - Technical Specifications of all materials to be supplied
 - Valid VAT / Sales tax clearance certificate ,Income Tax return, PAN card, Service Tax Registration Certificate
 - Bid documents duly signed & sealed on every page as token of unconditional acceptance of all Terms and conditions mentioned in the bid document.
 - **Indigenous Certificate**
 - Organizational profile
 - Balance sheets and profit & loss accounts
 - Certificate and proof as per qualification criteria

All the papers of bid documents **except the price bid should be duly signed and uploaded in **e-tender** portal. Hard copy (i.e EMD, Tender cost & signed e-tender document) shall be submitted to OREDA office at S-57, Mancheswar Industrial Estate, Bhubaneswar 751010 on or before the stated date in the manner prescribed elsewhere in the document.**

Price bid to be only filled up in the specified bid sheet and uploaded.

G. TECHNICAL BID:

The Electronic Form/Template of the bid for the Techno –Commercial bid, as available on the portal, shall be duly filled and scanned copies of documents in support of meeting the minimum qualifying requirement of the tender shall be given as attachments.

H. FINANCIAL BID:

- The Electronic Form/Template of the Price bid (as available on the portal) shall be duly filled in.
- Prices quoted must be firm and fixed. No price variation / escalation shall be allowed during process of completion of the project.
- **Any condition in regards to financial aspects, payments, terms of rebate etc beyond the prescribed financial terms of OREDA will make the bid invalid.**
- Therefore it is in the interest of the bidders not to write anything extra in the Price Bid except price.

I. ACCEPTANCE/REJECTION:

OREDA reserves the right to accept / reject any or all Tenders without assigning any reason thereof and alter the quantity of materials mentioned in the Tender documents at the time of placing purchase orders. Tender will be summarily rejected if:

EMD is not deposited either in shape of Bank Draft in favour of OREDA payable at Bhubaneswar. This shall not apply to those who are eligible for exemption from depositing EMD under NSIC etc. subject to submission of such exemption certificates.

Note: EMD against previous Tenders, if any, will not be adjusted towards EMD against this Tender.

- i) Complete Technical details are not enclosed.
- ii) Tender is received after the last date for what-so-ever reasons.

J. PROCEDURE FOR OPENING THE BIDS:

The procedure of opening of the bid shall be as under

- a. The ‘TECHNICAL BID " shall be opened at the time & date mentioned in the notice in the tender by OREDA in the presence of bidders, or their authorised representative.
- b. PRICE BID” shall be opened after evaluation of technical suitability of the offers. The date for opening of Price bid shall be communicated subsequently. Price bids of only those bidders shall be opened who qualify in the technical bid evaluation. If necessary, the firms may be called for Technical Presentation of their products as per the time intimated by OREDA. The successful bidders will be decided by the purchase committee /selection committee for two items i.e (i) Solar water Heating system alone (Price bid- Annexure- B-I (a) to B-I (e)) and(ii) Solar water heating system with HDPE tank (Price Bid Annexure-B-II(a) to B-II (e)) for smooth execution of work depending upon requirement of user/user’s organisation. The successful bidders should agree to the price finalised by the committee on the plumbing item of the annexure-B-III to complete the project.

Check list of documents to be submitted along with the hard copy of the bid

Sl. No	Particulars	Complied	Page No.
1	Cost of Tender document for Rs.10,500/- or exempt as admissible with proof.	Bank No Dt	
2	Acknowledgement for tender processing fee.	Bank No Dt	
3	Bank draft for Rs.1,00,000/-Rupees one lakh only towards EMD in shape of Bank draft	Bank No Dt	
4	Forwarding letter duly signed and stamped by the bidder		
5	Undertaking duly signed and stamped by the bidder		
6	Document stating the status of the bidder as manufacturer /systems integrator		
7	Copy of the PAN card of the bidder's firm		
8	Copy of the TIN No. of the bidder's firm		
9	Tax return, VAT/ STCC/E-submission, VAT clearance certificate		
10	Annual turnover and turn over in solar business, audited report		
	2013-14		
	2014-15		
	2015-16		
	Total		
11	Proof of installation of 2000LPD (40 sq meter collector area) or more . Copies of completion report.		
12	Proof of production capacity of Solar Water Heating System		
13	Valid test report/ certificate of BIS as per MNRE		
14	Willingness- Opening of service centre in the state		
15	Undertaking to supply Indigenous items as per relevant guidelines of MNRE, GoI		
16	Undertaking to unconditionally accept all terms and conditions of the bid document with copy of Board Resolution		

17	Power of attorney to sign the agreement on behalf of bidders		
18	Filled in bid document duly signed and stamped at the bottom of each page except the price bid format.		
19	Organizational profile containing the original documents defining the constitution or legal status, place of registration and principle place of business.		
20	Signed Technical bid in sealed envelop		
22	Proof of Quality assurance systems, organisation(ISO 9001:2008 certification)		
23	A self certification by an authorized person duly notarized to this effect that the farm have not been debarred / blacklisted by any Govt. Deptt, agency, PSUs / institution / agencies / autonomous organisations		

Signature of bidder with seal

Forwarding Letter
(to be submitted in the letter head of the bidder)

To,

The Chief Executive
Odisha Renewable Energy Development Agency (OREDA)
S.59. MIE, Bhubaneswar -751010
Odisha

Subject: Tender for Standard Rate Contract for Design, Supply, Installation, Commissioning and Maintenance for a period of 5 years of Solar Water Heating System in different Buildings/ locations in the state of Odisha vide tender call notice no 661 dated 06-03-2017

Sir,

Having studied the Tender document carefully I/we, the undersigned, offer to submit our tender for the work of Design, Supply, Installation, Commissioning and Maintenance for a period of 5 years of solar system in conformity with the aforementioned tender document.

I/We have also read the various provisions of the Tender and confirm that the same are acceptable to us including the provision of CMC. We further declare that any additional conditions, variations, deviations, if any, found in our Tender offer shall not be given effect to. We further understand that **any deficiency / illegibility in documents shall make our tender liable for rejection.**

I/we submit our tender understanding fully well that

- (a) The bid and other documents submitted along with the same will be subject to verification by appropriate authorities.
- (b) OREDA reserves the right to accept or reject any application or the bid process itself without assigning any reasons thereof and shall not be held liable for any such action.
- (c) Any genuine changes made by OREDA in the interest of the work with respect to the technical requirement during the course of project execution will be acceptable to us.

We hereby declare that all the information and statements made in this proposal are complete, true and correct and also accept that any misinterpretation contained in it may lead to our disqualification.

We hereby declare that our Tender is made in good faith and the information contained is true and correct to the best of our knowledge and belief.

Yours faithfully,

Signature of bidder

UNDERTAKING BY THE BIDDER

I/we here by undertake that

1. We have thoroughly read and examined the notice inviting tender and the tender document along with all its schedules, annexure etc.
2. The rates quoted by us are firm and final and are meant for execution of the allotted work within the time frame stipulated in the tender/work order.
3. All terms and conditions of the tender including the rates quoted by us shall remain valid for a period of one year.
4. In case our tender is incomplete in any respect or we violate any of the prescriptions given in the tender for submission of the same OREDA shall , without prejudice to any other right or remedy , be at liberty to forfeit the earnest money deposited by us.
5. In case of award of work in our favour OREDA shall have the right to convert the EMD deposited by us in to full or part (as the case may be) of the security deposit to be deposited by us against award of the work.
6. In case we fail to commence or complete the work as per the time schedules or fail to fulfil any of the terms and conditions given in the tender OREDA shall , without prejudice to any other right or remedy , be at liberty to forfeit the security deposit made by us against the award of the work.
7. I/We hereby declare that I/We shall treat the tender documents, specifications and other records connected with the work as secret/confidential and shall not communicate information derived there-from to any person other than a person to whom I/We have authorized to communicate the same or use the information in any manner prejudiced to the safety of OREDA/the State Govt.
8. I/We shall abide by all the laws prevailing at the time of the execution of the work and shall be responsible for making payments of all the taxes, duties, levies and other Govt. dues etc. to the appropriate Govt. departments.
9. Our state commercial tax / TIN registration no. is _____
and
CST registration No.

The PAN No. under the Income Tax Act is _____ and
Service Tax Registration No. is _____

10. I/We shall be responsible for the payment of the respective taxes to the appropriate authorities and should I/we fail to do so, I/we hereby authorize OREDA to recover the taxes due from us and deposit the same with the appropriate authorities on their demand.

Signature of bidder with stamp

Dated:

Letter of Authorization

(to be submitted in the letter head of the bidder)

To,
Chief Executive
Odisha Renewable Energy Development Agency
S-59, MIE, Bhubaneswar-751010
Odisha

Sub: Submission of Tender for Standard Rate Contract for Design, Supply, Installation, Commissioning and Maintenance for a period of 5 years of solar water heating system in different / locations in the state of Odisha

Ref: Tender call notice no661 date 06-03-2017

Sir,

I/we hereby authorize Ms. /Mr. _____ , Designation _____ of our company to sign all relevant documents on behalf of the company/firm in dealing with the above tender. She / He is also authorized to attend all meetings and submit technical and commercial information as may be required by OREDA in the course of processing of the tender.

We further authorize Ms. /Mr. _____ designation _____ of our company to make technical presentation on behalf of the company.

Signature of the authorized persons

1. _____
2.

Signature attested

Name and designation of the attesting officer with stamp

Yours faithfully

Head of the organization

DECLARATION

(to be submitted on the letter head of the company)

To,

Chief Executive
Odisha Renewable Energy Development Agency
S-59, MIE, Bhubaneswar, 751 010.
Odisha

Sub: Submission of Tender for Standard Rate Contract for Design, Supply, Installation, Commissioning and Maintenance for a period of 5 years of solar water heating system in different Buildings/ locations in the state of Odisha

Ref: Tender call notice no-661/OREDA dated-06-03-2017.

Sir,

I/we hereby declare the following in the context of the aforementioned tender that:

- a) The entire tender document has been discussed in the Board meeting and a resolution has been concurred for participation in the tender (copy enclosed)
- b) We are not involved in any litigation that may have an impact of affecting or compromising the delivery of services as required under this tender
- c) We are not blacklisted / defaulted in any manner by any Central / State Government / Public Sector Undertaking in India.
- d) In case any false documents submitted and found any time in future the firms shall be liable to be proceeded against as per prevailing laws.

Yours faithfully,

Authorized signatory (Stamp)

4 ELIGIBILITY CRITERIA:-

In order to be eligible to participate in this tender for rate contract a bidder must have the following eligibility criteria

1. The firm should be solar thermal device manufacturer/authorized dealer .
2. Must have BIS certificate on solar water heating system as per MNRE guideline.
3. The firm must have a minimum total turnover of Rs1 crore over last three years.
4. The firm must have installed at least 2000 LPD (40sq meter collector area) Solar Water Heating System.

5. ACCEPTANCE/ REJECTION OF THE BID DOCUMENTS:

Chief Executive, OREDA reserves the right to reject or accept any bid or annul the bidding process at any time prior to award of contract, without having prejudice of incurring any liability to the affected bidders or any obligation to inform the bidders.

6. COMMERCIAL TERMS& CONDITIONS:

Rate:

The offer should indicate the unit cost of the system, Installation & Commissioning charges, CMC Charges and taxes & duties separately. The unit cost must be inclusive of packing, forwarding, loading & unloading charges, cost of insurance and transportation FOR destination where the system will be installed as per the work order.

Sales Tax & Duties etc.:

All Taxes and duties as prescribed both under Central and State Government sales tax rules would be applicable.

Earnest Money Deposit:

- Earnest money deposit as specified above is required to be deposited along with the hard copy of bid without which the bid will not be accepted. No interest will be payable for the EMD amount under any circumstances.
- E. M. D would be adjusted against security deposit in case of successful bidders.

- E. M. D would be forfeited in case of non- compliance of the purchase order by the successful bidder.
- In case of claim for exemption from deposit of Earnest money sufficient proof in support of claim for exemption of EMD as prescribed in Govt. of India Notification is to be attached with the bid.

Security Deposit/ Performance Guarantee Fees:

The successful bidders must deposit **two numbers of bank guarantees** (Annexure-B) towards Security cum Performance Guarantee fees with the Chief Executive, OREDA, Bhubaneswar along with bills, challans and all other documents as per payment clause before processing of payment as follows

- i) 7.5 % of the ordered value in shape of irrevocable Bank Guarantees with **5½ years validity** from the date of supply, installation and commissioning till the completion of respective warranty and CMC period of the composite system.
- ii) 2.5 % of the ordered value in shape of irrevocable Bank Guarantees with **10½ years validity** from the date of supply, installation and commissioning till the completion of respective warranty

7. WORK EXECUTION SCHEDULE:

- All ordered systems must be supplied / installed in all respects within 90 days of receipt of firm work order from OREDA.
- Under exceptional circumstances the period of execution can be extended reasonably only upon written request by the vendor.
- Upon intimation about commissioning of the systems by the executing firm a joint inspection will be carried out by the representatives of the executing firm, OREDA and User organization.
- The issuance of a JCC shall, in no way relieve the executing firm of it's responsibility for satisfactory operation of the power plant.

8. ALLOCATION OF SUPPLY / INSTALLATION & EXECUTION:

All supply / installation orders shall be placed with the state local registered office of the qualified empanelled bidders having valid Odisha TIN/ OVAT as per the FD circular no 5439 dtd 25.2.2014.

- All successful bidders conveying acceptance to L1 prices for different SPV systems under this tender shall be duly empanelled and arranged in the order of their quoted prices as L1, L2, L3,
- **Ln. The vendor should have willingness to execute the work even for single system**

at L-1 price.

- Depending upon the quantum of materials required as well as the geographical spread of the installations the first batch of the order will be placed on one or more empanelled bidders basing on the order of their empanelment.
- Placement of subsequent orders on the same bidders will be subject to timely execution and performance in respect of the previous work order.
- Placement of subsequent work orders on bidders who have not received any order will be subject to the quantum of materials required as well as geographical spread of the work
- The vendors is to submit acceptance of the work order/purchased order within 15 days from the date of issue of work/purchase order failing which the order is treated to be cancelled. The vendor will be debarred from the empanelment list.

9. VALIDITY OF OFFER:

The offer must be kept valid for a period of one year from the date of opening of the technical bid or till the completion of the project whichever is later. No escalation clause except the admissible tax component under the period of consideration would be accepted.

10. VAT:

The bidders must submit attested copy of valid up to date VAT/STCC clearance certificate along with the bid. The bid would not be considered without this document. The original certificate would be produced at the time of opening of the bid or before placement of purchase order, if required. Subsequent to selection, all bidders are required to register under OVAT if not registered earlier.

11. WARRANTY:

- The complete system should be warranted against any manufacturing defect or bad workmanship at least for a period of 5 (five) years from the date of supply/commissioning of the systems.
- SPV modules must be warranted against any manufacturing defect of bad workmanship for a period of 10 years.
- Warranty certificate to the above effect must be furnished along with the commissioning reports. Any defect noticed during warranty period should be rectified / replaced by the supplier free of cost upon due intimation by OREDA.

12. PENALTY AND TERMINATION OF CONTRACT:

- The systems shall be supplied, installed and commissioned within the scheduled time. If the bidder fails to adhere to the schedule, OREDA shall without prejudice to its other remedies under the contract deduct from the contract price as liquidated damages a sum equivalent to 1% of the delivery price of the delayed goods or unperformed services for each week of delay until actual delivery or installation/commissioning up to a maximum deduction of 5% of the contract price

for delayed goods or installation and commissioning. Once the maximum is reached (i.e 5 weeks of delay) OREDA may consider termination of the contract and forfeit the security deposit without prejudice to the other remedies of the contract.

- However, Chief Executive, OREDA may at own discretion allow reasonable time extension upon written application of the supplying firm. If the delay is considered intentional or due to the negligence of the vendor, no extension can be allowed with imposition of penalty. If the delay is considered to be genuine time extension can be allowed without imposition of penalty.

13. FORCE MAJEURE:

The supplier of the SPV system shall not be charged with liquidated damages nor shall his security for performance be forfeited when failure of the supplier in making delivery is due to any event beyond the control of the supplier and could not have been foreseen, prevented or avoided by a prudent person. These include, but are not restricted to acts of nature, acts of public enemy, acts of Government, fires, floods, epidemics, strikes, freights, embargoes and unusually severe weather.

14. INSPECTION:

- All tests and inspections shall be made at the place of delivery. Officers authorized by OREDA shall be entitled at all reasonable time to inspect and supervise and test during erection and commissioning. Such inspection will not relieve the executing firm of their obligation in the contract.
- OREDA shall have the right to have the tests carried out at its own cost by an independent agency at any point of time.

15. PAYMENT:

Payment for the work (excluding CMC charges) under normal circumstances will be done as detailed below;

- i) **90%** of the total value of order (excluding AMC charges) after commissioning of the project. The check list of documents to be submitted with the bills for release of first instalment is annexed at Annexure- D
- ii) Balance @ **10%** of the total value after successful functioning of the system for six months. Submission of all documents as per check list given at Annexure E

16. EXECUTION:

Execution of work shall be carried out in an approved manner as outlined in the technical specification or where not outlined, in accordance with relevant Indian Standard Specification, to the reasonable satisfaction of the Authorized OREDA Officer.

17. COMPREHENSIVE MAINTENANCE CONTRACT (CMC):

- The bidder must enter into a Comprehensive maintenance contract for the specified period at the time of execution of the order. Offer without such CMC shall not be considered.(sample format of CMC enclosed at Annex - C).
- The scope of CMC must cover supply of spare parts (including wherever necessary) / services during the contract in force. Order shall be placed on bidders who agree to offer such CMC. The CMC charges quoted by the bidder must be realistic in view of actual rendering of after sale services. The payment of annual maintenance charges under the Comprehensive Maintenance Contract shall depend upon the functionality of the system duly certified by the concerned Authorised officials of OREDA.

18. LIMITATION OF LIABILITY:

OREDA, will, in no case be responsible for any accident fatal or non-fatal, caused to any worker or outsider in course of transport or execution of work. All the expenditure including treatment or compensation will be entirely borne by the Executants. The Executants shall also be responsible for any claims of the workers including PF, Gratuity, ESI & other legal obligations.

19. DISPUTE:

For adjudication of any dispute between OREDA and the bidders arising in this case, reference can be made to any Law courts under the jurisdiction of Odisha Minicourt only. The Chief Executive, OREDA reserves the right to accept or reject any or all bids without assigning any reason thereof.

Chief Executive

I/We have carefully read and understood the above terms and conditions of the bid and agree to abide by them.

SIGNATURE OF BIDDER WITH SEAL

A. TECHNICAL SPECIFICATIONS FOR SOLAR WATER HEATING SYSTEM

specification

FLAT PLATE SOLAR WATER HEATING SYSTEM

The solar water heating system of 100 - 1000 LPD capacity at 60 ° will be installed any location in the state of Odisha.

STANDARDS

The details of the standard which contain minimum performance requirement along with the test method are as follows.

1. Solar Flat Plate Collector

- a) IS 12933 (Part-1): 2003 , solar flat plate collector – Specification , part 1-requirement
- b) IS12933 (Part-2) :2003 , Solar flat plate collector-Specification, Part-2-Components
- c) IS 12933(Part-3) :2003 Solar flat plate collector –Specification ,part-3- Measuring Instruments
- d) IS 12933 (Part-5) :2003 , Solar flat plate collector-Specification, part-5-
- e) test method

2. MNRE Specification for test procedure

Test procedure for Thermo-syphonic solar water heating systems are available on MNRE web sitewww.mnre.gov.in should be followed.

Test Report & Testing laboratory /center

The Solar Collector must be tested at any test centers in the country which is recognised by BIS for carrying out certification testing for solar water heating system as per Indian Standard. Only Collector as per BIS specification No- 12933 solar flat collector and also BIS marked will be supplied.

SOLAR WATER HEATING SYSTEM

- i. Natural Circulation (Thermo syphon) and
- ii. Pressurized system
- iii. Forced circulation system

Capacity & Temperatures: 100 LPD to 1000 LPD and 60 degree C

Sl. No.	Item and Specifications	Natural Circulation (Thermo syphon)
1.	Supply of collectors and stand with installation	As per system capacity
	Absorber: cu-cu only: Box	

	Aluminium (ISI Mark only) IS: 12933	
2.	Supply and installation of insulated storage tank with stand	Capacity same as per system capacity
	Material of construction	Stainless steel – 316
	Insulation with thickness of material	Rock wool 100 mm / PUF 50 mm
	Density of insulation	Rock wool – 48 Kg / m ³
		PUF-40 Kg / m ³
	Insulation cover	Aluminium sheet 22 swg.
3.	Supply control instruments with installation.	1-set for each system
	• Tap (brass Tap)	1 No.
	• Gate Valve (Brass, 1 inch, ISI Mark)	2nos.
	• Non return valve (ISI mark)	1 No.
	• Air vent	1 No.
	• Strainer (ISI Mark)	1 No.
	• Temperature Gauge ISI mark	1 No. For above 500LPD system

Other requirement of water heating system

1. Overall dimension of collector

Size	Length (in mm)	Height(in mm)	Width(in mm)
A	1860± 10	100±10	1240± 10
B	2120 ± 10	100± 10	1040± 10
C	2050± 10	100± 10	930± 10

2. **Cover plate :-** The cover plate shall be single piece tempered / toughened glass and minimum of 4 mm thick ,free from bubbles and rough surface as per the latest BIS specification ((IS: 12933 part-2: 2003)The solar transmission of the cover plate shall be minimum 82% at near normal incidence.

3. **Collector Box: -** The collector box shall be made of aluminium section only. Type, grade, size, workmanship and finish of the material used shall be as per latest BIS specification. The minimum thickness of Aluminium shall be as under.

Channel Section for sides	1.6mm
Sheet for bottom	0.7mm
Support for glass retaining	1.2mm
Sheet for entire body	1.0mm

- c) Silicon rubber

Grommet and gaskets shall be capable of withstanding temperature up to 125° C and shall conform to thermal shock test.

8. **Header flanges:** -Copper/brass flanges of 62mm ± 3mm diameter and minimum thickness of 4mm with provision for 4nos of brass nut and bolts with diameter of 5mm -6mm shall be used. Flanges shall be brazed to header and brazing tested for leakage to test pressure. In no case crude solder flanges shall be used. Assembly of the flanges should be at right angle to the header area to ensure proper assembly at the side of the insulation.

9. **Assembly of the Collector:-**

- a) The collector shall be assembled in such a way that the weight of the absorber is distributed uniformly on the side wall of the collector box.
- b) The entire assembly shall be free from surface defects. All sharp edges and corners shall be rounded off. The exposed surfaces shall be properly made corrosion resistant.
- c) The air gap between the cover plate bottom and the absorber surface shall be within 20mm to 40mm.
- d) The glass should be firmly held, without strain taking in to account the expansion of glass. Top surface along with the edge between the glass and the aluminium angle shall be caulked with suitable sealant such as zinc oxide based or rubber based or silicon rubber based or epoxy based compound.

10 **Gasket for Flanges:-**3mm thick compressed asbestos fibre or Neoprene rubber gasket shall be used for sealing the joints between flanges.

11.**Collector Support frame:** -The structure shall be in a position to withstand wind velocity of 200 Km/hr. The structure shall be made with angle iron stronger than 35mm X 35mm X 3mm and shall have the vertical support at top and bottom edge of the inclined plane of the collector at a distance of 2.5 m or less. The vertical support shall be firmly grouted to the roof or in the ground in case of ground mounted system. The grouting blocks shall be minimum 30cm X 30cm X 30cm and finished properly. In case of grouting is carried out on a roof already water proofed with asphalt, the back support of the collector may be anchored to the parapet or the size of the grouting block shall be increased to provide for a dead load weight anchoring of 75 Kg per leg of the vertical stand.

The collector support frame shall be rectangular shape i.e having all four sides touching the collector edge. The cement pedestals should be made after chipping of the existing rooftop to provide proper gripping and strength. Structure should be such that collector's bottom side is at least 30 cm above the ground/roof level. In case of inclined roof, the collector housing frame along with the vertical angle shall be mounted & fixed using suitable necessary structure keeping in view the load bearing capacity of the roof top ensure the stability against storm. The collector should be properly clamped and tightened with frame and supporting structure at both the ends by 20mmX 2mm size MS strip consisting rubber packing to avoid chemical reaction between the collector bodies and clamp. Last row of collector supporting structure should be grouted throughout its length opposite to collector facing with c.c work ratio 1:2:4 of size 30cm X 30cmX 30cm (d x h i.e height X width) and then plaster with cement.

12. **Painting of stand:** -Proper cleaning and degreasing of the surface should be done before painting. Two coats of zinc chromate red oxide primer shall be applied followed by

one coat of enamel paint. Suitable anticorrosion paint should be applied after proper treatment.

13. STORAGE TANK

Material : De-Pressurized

The tank shall be made up of stainless steel (SS304/316).

The storage tank for 100/ 200 litres capacity shall be made of 22 SWG stainless steel only. Above 200 and up to 500 litres capacity the storage tank shall be of stainless steel of thickness 20 SWG, above 500 and up to -1000 liters, it shall be of 16 SWG. .Support structure shall be designed properly to withstand the load of the Storage Tank, wind speed and the stored water. Sucket and internal fittings

Insulation: - Insulation should withstand temperature of 100 ° C. Thin polythene sheet shall be used as covering between the glass wool and the cladding sheet besides the retaining materials such as chicken mesh etc. Aluminium sheet of thickness, 22 SWG / GI sheet of minimum 24 SWG shall be used for cladding the tank insulation. External of the tank should be properly insulated so that hot water temperature does not decrease by more than 5 degree C in about 16 hours times.

The storage tank shall be properly installed at site using enamelled coat appropriate size angle iron stand, girder cement pedestals of 1:2:4 ratio or any other specific provision suitable to site to ensure the stability against heavy storm etc.

14. Piping:-

½ inch to 2 inch dia ISI marked GI pipe , medium class of IS 1239 shall be used for piping. 50 mm thick rock wool insulation of 48 Kg/cum density be used for hot water pipes. Thin plastic sheet shall be used as covering between rock wool and aluminium cladding besides other retaining materials like chicken mesh etc. 26 SWG thick aluminium sheet shall be used for cladding the insulated pipe. The pipe line should be properly supported and fixed with clamp with the help of suitable size stand/civil structure (cement concrete ratio 1:3: 4). ISI mark gunmetal strainer of standard make should be fitted in the main cold water supply line before the system. **ISI mark CPVC pipes and fittings can be used in hot water line .**

15. Valves/Nipple/tees/bend/taps:-

Gunmetal valve as per ISI specification shall be used. Nipple/tees and bends shall be of medium class G I (B-class) /brass or copper. Gunmetal valve in each row shall be provided. TAPs of stainless steel ISI mark or reputed make shall be provided. Good quality CPVC fittings can also be used of appropriate sizes.

16. Temperature gauge:-

Temperature gauge (ISI mark):- One for hot water storage tank/outlets – dial type – duly calibrated and suitable for temperature ranges (0 to 120 ° C)

A. TECHNICAL SPECIFICATIONS FOR HDPE TANK

Sl No	Maximum capacity(in liter)	Overall Diameter in MM	Overall Height in MM	Minimum Internal Dia of Man hole/hand hole in MM	Minimum Wall and bottom thickness in MM	Minimum Weight of tank
1	200	650-850	490-690	265	3	7.8
2	300	650-850	700-900	265	3	9.0
3	400	700-980	700-950	265	3.5	15.0
4	500	800-1140	625-1025	370	4	18
5	1000	1000-1200	1050-1350	370	4.5	33

The stand should be of MS. Proper cleaning and degreasing of the surface should be done before painting. Two coats of zinc chromate red oxide primer shall be applied followed by one coat of enamel paint. Suitable anticorrosion paint should be applied after proper treatment. The supporting structure should be grouted with c work ratio 1:3:4 of size 30cm X 30cm X 30cm (d x h i.e height X width) and then plaster with cement. The structure shall be in a position to withstand wind velocity of 200 Km/hr..

The support frame shall be rectangular shape. The cement pedestals should be made after chipping of the existing rooftop to provide proper gripping and strength.

Drawing For structure

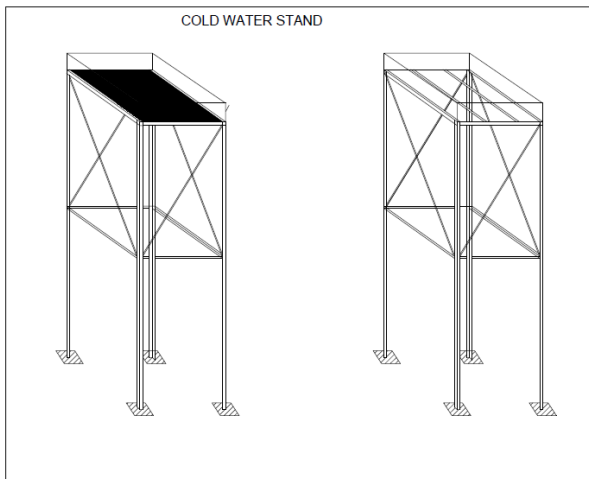

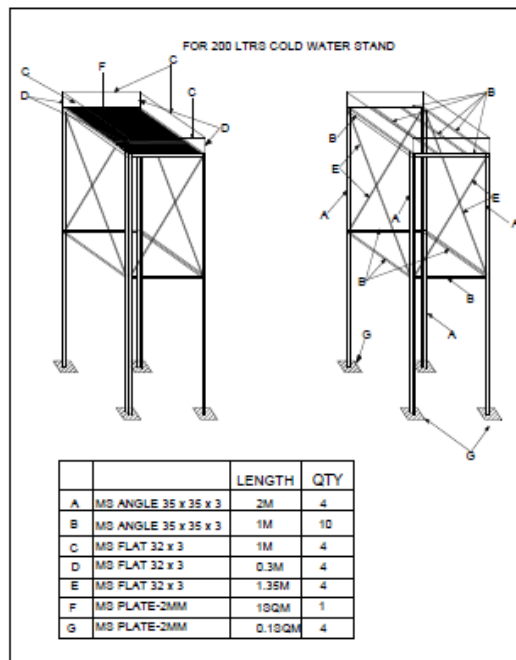
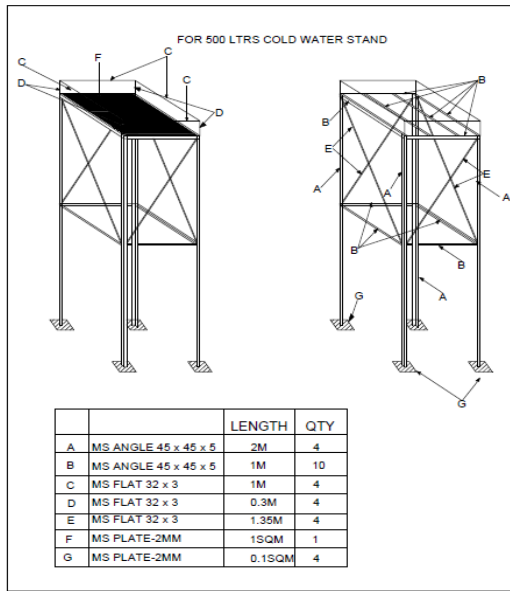

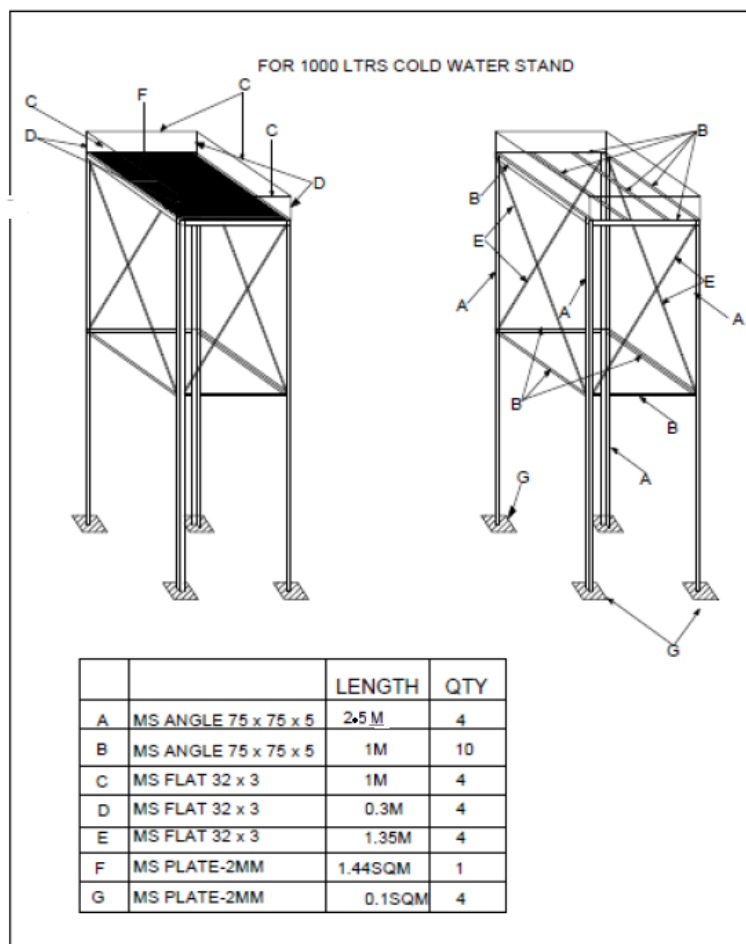
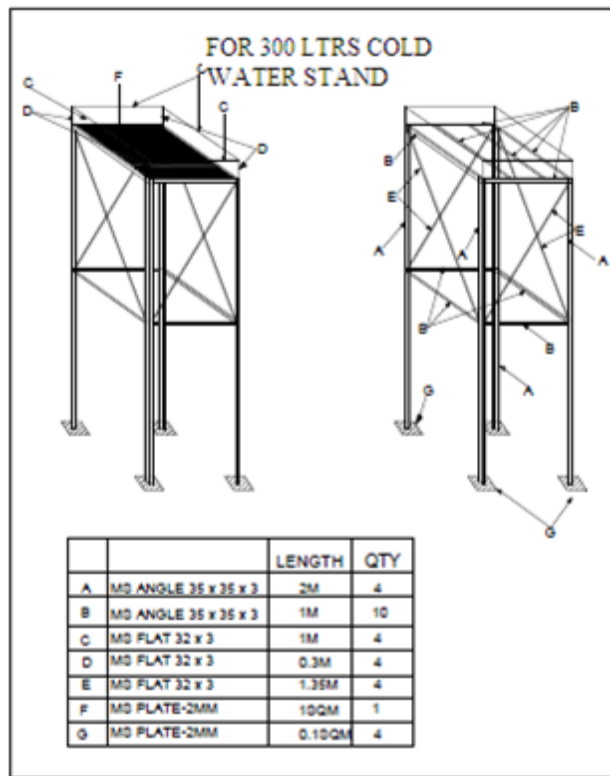

ANNEXURE-D

Check List for submission of information/documents after commissioning of the project

S/N	Information/document to be submitted	Whether submitted
1	Site Details Name of the location Postal Address Phone No. Fax No. Name of the OIC/Contact Person	
2	System details a. Solar Collector Make- Year of manufacturing test report from MNRE authorised test centre Serial Number b. Hot water tank Make Model Yr of manufacturing Serial Number – c. Cold water tank if installed Make Model Yr of manufacturing Serial Number –	
3	Warranty/ Guarantee of the composite system	
4	Training details Date of training No. of persons trained Name & designation of the persons	
5	Service Centre Details Name /address / contact details of the service centre that will cover the project Name & mobile No. of the person of the service centre in-charge of the project	

Annexure E

SRI No.	Document to be submitted	
1	Joint commissioning & system handing over report (in prescribed format)	
2	Signed Copy of CMC	
5	Performance report after six months of daily/monthly wise output / consumed with proper reason in case of short fall.	

ANNEXURE- F

**ORISSA RENEWABLE ENERGY DEVELOPMENT AGENCY
S-59, MANCHESWAR INDUSTRIAL ESTATE,
BHUBANESWAR-751010**

FORMAT FOR WARRANTYCARD

1. Name & Address of the Manufacturer/Supplier of the System	
2. Name & Address of the place	
3. Date of installation of the system	
4 Details of Solar Collector (s) supplied in the system Make (Name of the manufacturer) Model Serial No. (s) Warranty valid up to	
5 Details of HDPE TANK & STAND (s) supplied in the system Make (Name of the manufacturer) Capacity Warranty valid up to	
6 Designation & Address of the person to be contacted for claiming warranty obligations.	

(During the warranty period MNRE / OREDA authorized Officer / Users reserves the right to cross check the performance of the system as per the minimum performance levels specified.)

Signature & Stamp

VENDOR

Place:

date:

**Finance Department Office Memorandum 4939 dtd 13.2.12, Govt of
Odisha
Model Bank Guarantee Format for Performance Security
[Ref Para 22(i1)]**

To

WHEREAS----- (name and address of the supplier) (hereinafter called "the supplier") has undertaken. in pursuance of contract no----- dated----- to supply -----(description

of goods and services) (herein after called "the contract")' AND WHEREAS it has been -stipulated by you in the said contract that the supplier shall furnish you with a bank guarantee by a scheduled commercial bank recognized by you for the sum specified therein, as security for compliance with its obligations in accordance with the contract;

AND WHEREAS we have agreed to give the supplier such a bank guarantee; NOW THEREFORE we hereby affirm that we, are guarantors and responsible to you on

behalf of the supplier. up to a total of ----- .(Amount of the guarantee in words and figures).and we undertake to pay you. Upon your first written demand declaring the supplier to be in default under the contract and without cavil or argument, any sum or sums within the limits of (amount of guarantee) as aforesaid. without your needing to prove or to show grounds or reasons for your demand or the sum specified therein.

We hereby waive the necessity of your- demanding the said debt from the supplier before presenting us with the demand. We further agree that no change or addition to or other 'modification of the terms of the contract to be performed there under or of any of the contract documents --which may be made between you and the

supplier shall in any way release us from any liability under this guarantee and we hereby waive notice of any such change. Addition or modification.

This guarantee shall be valid until the day of-----20----- Our branch at * (Name & Address of the _____ * branch) is liable to pay the guaranteed amount depending on the filing of claim and any part thereof under this Bank Guarantee only and only if you serve upon us at our----- * branch a written claim or demand and received by us at our

_____ * branch on or before Dt.-----otherwise bank shall be discharged of all liabilities under this guarantee thereafter.

(Signature of the authorized officer of the Bank)

Name and designation of the officer

Seal.name& address of the Bank and address of the Branch

Annexure-C

COMPREHENSIVE MAINTENANCE CONTRACT (CMC) FOR MAINTENANCE OF SWHS
 SUPPLIED & INSTALLED BY MS _____ at
 _____ Block _____ District _____

FOR FIVE YEARS

This Comprehensive Maintenance Contract (CMC) is executed between the Odisha Renewable Energy Development Agency (OREDA), S-59, Mancheswar Industrial Estate, Bhubaneswar-10 represented by its Deputy Director (Tech.), Division-I hereinafter called as 1st Party and MS. _____ hereinafter called as 2nd Party, for maintenance of Solar Water Heating system for a period of five years with effect from _____, supplied and installed at _____ Vide Purchase Order No. _____ dt. _____.

The 2nd party will maintain the Solar Water Heating system as per the terms and conditions mentioned hereunder.

1. It has been envisaged in the Purchase Order No. _____/OREDA, dated. _____ Under Clause No. _____ that the Solar Water Heating system shall be warranted against any manufacturing defect and bad-workmanship at least for a period of five years from the date of commissioning. The systems have been commissioned and handed over to the 1st party through the Asst Director (Tech), posted at DRDA on _____. The 2nd party is fully responsible for their trouble-free performance of all the components during the warrantee period. .
2. The solar collectors and hot water storage tank as stipulated in the _____ paragraph of the said Purchase Order under the Clause No. _____, the Solar Water Heating system are covered under warranty for a period of at least five years from the date of use, it is natural that these are to be covered under Warranty up to _____

The 2nd party is fully responsible for any defect noticed within the warranty period and is liable for rectification/replacement of the defective components/systems with free of cost.

3. The 2nd party should conduct at least one training programmes for the users/technical personnel and field functionaries of OREDA, on day-to-day repair and maintenance of the system.
4. The PGF amount @ 10% of the ordered value shall be kept as fees towards Performance Guarantee for a period of five years of maintenance. After expiry of the maintenance period of five years, which remains valid up to _____ the above PGF shall be returned to the 2nd party thereafter only.

If the maintenance of the Solar Water Heating system found to be unsatisfactory by the 2nd party, the 1st party will have the liberty to encash and forfeit the PGF deposited/furnished, in full or part as may be decided by the 1st party..

5. The CMC includes repair/replacement of all spares and consumables,
6. The 2nd party shall undertake Preventive/Routine Maintenance work of the of Solar hot water heating system This shall be done at least once in every six month and shall include activities such as cleaning and checking the health of the system, cleaning of collector surface, and any other activity that may be required for proper functioning of the Solar hot water heating system as a whole. The 2nd party shall forward report to the 1st party in the prescribed format attached herewith (format-1) on every succeeding six months.
7. Whenever the complaint is lodged by the user, the 2nd party shall attend within 5-days from the date of receipt of the complaint and in any case the breakdown shall be rectified within a period not exceeding 7-days from the date of complaint. The 2nd party shall furnish the status report after the repair of works which shall invariably bear the signature of the institutional head , or his representative.
8. For carrying out the CMC effectively, the 2nd party shall establish at least one service center deployed within the State. The 2nd party shall maintain the following facilities at the service center for ensuring highest level of services to the end user.
 - (a) Adequate trained manpower specifically trained by the 2nd party for carrying out the service activities.
 - (b) Adequate provisions for record keeping, which shall inter-alia, include the following.
 - (c) Adequate spares for ensuring least down time of a individual component.
 - (d) The service center shall send summary service reports to 1st party on half yearly basis. These reports shall include the following information:
 - ❖ Number of complaint received during the period of reporting.
 - ❖ Number of complaints attended during period of reporting.
 - ❖ Major cause of failure, as observed.
 - ❖ Major replacement made during the reporting period.
 - (e) The records maintained at the service center shall be available for scrutiny of authorized representatives of the 1st Party.
 - (f) The date of CMC, maintenance period shall begin on the date of actual commissioning of the solar hot water heating system.
9. Separate bills/Invoices in triplicate towards CMC cost are to be submitted by the 2nd party to 1st party for effecting payment, after end of the year from the date of maintenance of the systems as per price quoted in the price bid ..

10. Certificate in support of successful maintenance of the system (s) shall be obtained from the user as explained above, which should be countersigned by the Assistant Director (Technical), RE Cell, DRDA, _____ in token of verification of maintenance done.
11. It will be the liberty of the 1st party to cross check the systems maintained by the 2nd party. Random verification of the maintenance may be carried out by the 1st party wherever necessary.
12. The 2nd party may continue to maintain the Solar Water Heating System after expiry of the maintenance period of five year, provided the beneficiaries/1st party desires.
13. For adjudication of any dispute between the two parties arising on execution of this CMC, the matter shall first be brought to the notice of Chief Executive/Chairman, OREDA
14. In case, there will be no amicable settlement of the issue, the matter can be referred to the Court of Law having jurisdiction at Bhubaneswar only.
The Comprehensive Maintenance Contract is signed jointly between the two parties today i.e. on dated. _____ day of 2015

For and on behalf of Odisha
Renewable Energy Development
Agency (OREDA), BBSR
(1st Party)

For and on behalf of
M/S.
(2nd party)
(Seal)

Dy. Director (Tech.)
Division-I
(Seal)

Witness

Dy. Director (Tech.), Division-II ,OREDA(Seal)

